

Technical Publication

Title: On-Site and On-Line Spectroscopic Monitoring of Toxic Metal Ions
Using Fiber Optic Ultraviolet Absorption Spectrometry

ASA Publication Number: 1

Presented at: Second International Symposium
Field Screening Methods for
Hazardous Wastes and Toxic Chemicals

Note: This document was originally published by
Biotronics Technologies, Inc. in conjunction
with the ChemScan Process Analyzer
technology base, now owned by Applied
Spectrometry Associates, Inc. Please direct
all inquiries and correspondence to:

Applied Spectrometry Associates, Inc.
W226 N555G Eastmound Drive
Waukesha, WI 53186

Phone: (414) 650-2280
FAX: (414) 650-2285

**ON-SITE AND ON-LINE SPECTROSCOPIC MONITORING
OF TOXIC METAL IONS
USING FIBER OPTIC ULTRAVIOLET ABSORPTION SPECTROMETRY**

**Dr. Kenneth J. Schlager
Biotronics Technologies, Inc
12020 W. Ripley Ave.
Wauwatosa, WI 53226
(414) 475-7653**

**Bernard J. Beemster
Beemster & Associates
10062 N. Sunnycrest
Mequon, WI 53092
(414) 242-9101**

Presented at:

**Second International Symposium
Field Screening Methods
for
Hazardous Wastes and Toxic Chemicals**

**Las Vegas, Nevada
February 12-14, 1991**

I. The Need for On-line Monitoring of Heavy Metals

Heavy metals are common by-products in industrial operations. It is possible for these substances to enter the environment as a result of wastewater discharges from cleaning, plating or other industrial operations or after being leached from industrial waste piles or pits.[1] Several heavy metals such as chromium, copper, lead, mercury and zinc are listed as priority pollutants by EPA and require monitoring for NPDES permit compliance or for compliance with point source discharge pretreatment requirements. [2] Leachate from solid waste landfills often contain high concentrations of metals such as iron and manganese, as well as trace concentrations of other metals such as copper, nickel, and lead.[3] Measurement of metals such as chromium, lead, mercury, and iron are typically performed to characterize the quality of drinking water and ground water.[4]

Although Atomic Absorption Spectrometry is the typical method of metals analysis required for compliance reporting and other official purposes [5], this method is not practical for continuous on-line monitoring in multi-constituent media due to sample preparation requirements and apparatus that can handle only a limited number of samples. Another limitation is the need to change lamps if more than one metal is to be monitored. Multiple units would be required for on line analysis of more than one metal. This method is also impractical for field use due to the controlled environment, peripheral equipment, power, gas supply and operator skill levels required.[6]

Nevertheless, some industrial firms want an inexpensive but reliable way to monitor discharges for the presence of specific heavy metals for internal record or control purposes where immediate results can be made available without the need for sample extraction and processing prior to analysis. Such techniques may also be of interest for field testing to screen for discharge compliance or groundwater quality, especially if the apparatus required is transportable and capable of providing results that can approximate those obtained in the laboratory.

Electronegative metals with a density greater than 5 gm/cm³ are termed the heavy metals. These elements are found at the center of the periodic table, with the degree of electronegativity increasing from left to right.[7] Most of the heavy metals are also classified as one of the "transition" elements. Although the electronegative elements lose electrons with great reluctance, they do tend to form ions when dissolved in water. These ions attract electrons strongly, and have the tendency to form ligands, as portrayed in Figure 1, in which several water molecules are wrapped around a central cation and held together with unique coordinate covalent bonds.[8]

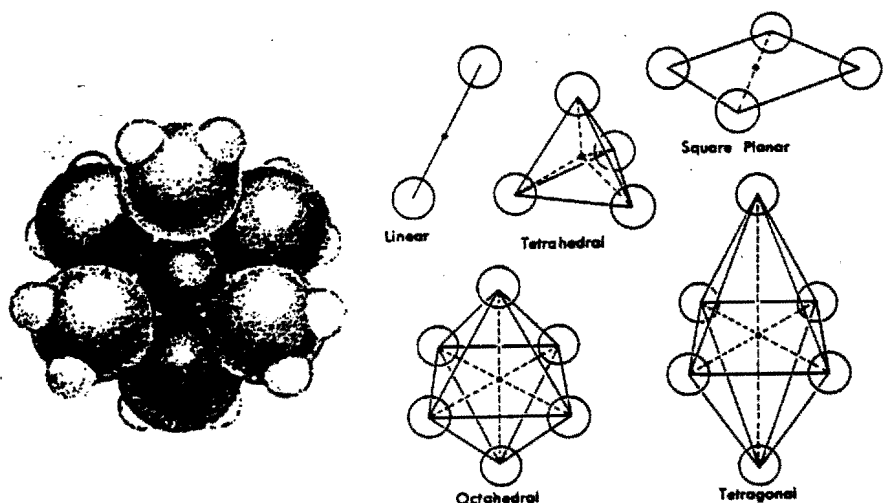

Figure 1. Ligands are central cations, surrounded by water molecules. Several possible geometric arrangements are shown.

II. Detection of Absorption Spectra

Absorption in the ultraviolet and visible region of the spectrum is a result of the changes in energy levels that occur in the bond structures and valence electrons of atoms when in contact with a source of ultraviolet-visible light. The energy changes occur in the outermost orbital, which consists of two high energy levels and three lower energy levels. Electrons will normally be found in the lowest energy level, but can become "excited" from absorption of a photon of electromagnetic energy from light in the proper frequency, causing the electron to temporarily occupy one of the higher energy levels.[9,10,11] Many heavy metals have strong absorption spectra in the ultraviolet-visible region due to the formation of ion complexes and ligands in water. It is well known that many of the heavy metals classified as transition elements possess the characteristic of forming complexes that are highly colored, that is, they absorb light in the visible wavelength range which is one reason why they are often used in pigments and dyes.[12]

The term "absorption" refers to the characteristic of allowing only some fraction of light at certain wavelengths to pass through an otherwise transparent substance (or be reflected off of a solid), the balance being "absorbed" by the substance. Thus, absorption is the inverse of transmittance, and solutions that are fully transmissive within a certain wavelength range will not absorb any light within that range. Conversely, solutions that fully absorb within a certain wavelength range will not permit any light within that range to be transmitted through the solution.[13] An elementary example can be seen in Figure 2, which compares the percent of visible light transmitted by a blue color chip compared to the light absorbed by that same chip. If we were unable to actually see the chip, we could still draw a conclusion concerning the color simply by observing the pattern of transmittance or the inverse pattern of absorption.

Chemical analysis using ultraviolet-visible absorption spectra relies upon the same basic principals used for color analysis, but with far more attention to relative absorption characteristics at many specific wavelengths over the entire ultraviolet and visible range (Figure 3). It is possible to analyze solutions qualitatively and quantitatively based on the pattern of absorption observed for the solution across this wide range of wavelengths, but special apparatus is required to detect the spectra and interpret the information. The absorption observed will be a function of all of the absorbing components within the solution, which complicates the problem of analysis. [Note 1]

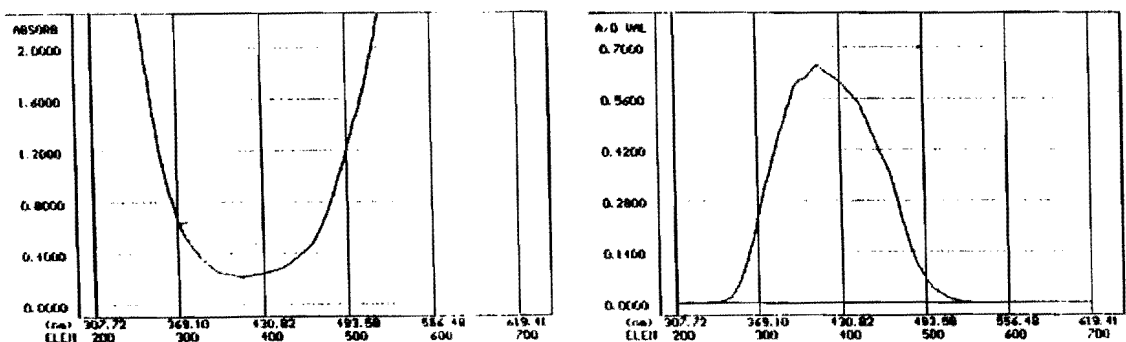

Figure 2. Absorption and transmittance of a blue standard.

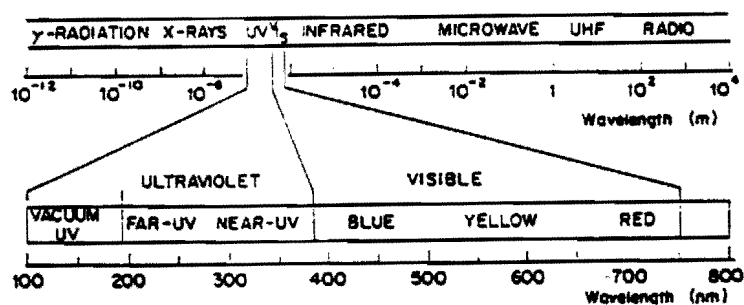

Figure 3. Ultraviolet-visible wavelength range.

III. Apparatus Required for Detection of Heavy Metal Spectra

The pattern of absorption (or transmittance) across a range of wavelengths defines an absorption spectrum for the substance being analyzed. If the substance is an element dissolved in a transparent solvent, such as pure water, the absorption spectrum that can be observed using the appropriate equipment defines the absorption spectra for that element (in that solvent). Figures 4 through 8 show the absorption spectra of chromium, copper, iron, mercury and zinc in pure water.

Figure 6 shows several spectra for iron, each for a different concentration ranging from .1 ppm to 2 ppm. Two observations can be made. First, no matter what the concentration is, the absorption spectra for iron has features that form a distinct pattern. (The graphics and scale used result in some loss in visual feature detail which can only hint at the extensive feature detail that is available for analysis in the form of numerical values for each spectra.) It is possible to define the common aspects of the spectral patterns in mathematical terms, so that any spectra that conforms to the resulting mathematical model will be recognized as "iron". If an analyzer can detect the spectra of an unknown substance (in the same solvent), the pattern can be evaluated in terms of iron by observing significant features of the absorption pattern for the unknown substance, then comparing these features to the model that was developed to describe iron.

Furthermore, it is possible to approximate the concentration of the unknown substance if it has been recognized as iron. If information is available that defines the relative position (intensity) that has been previously observed for the iron patterns at known levels of concentration, an interpolation can be made for a similar pattern falling between two known patterns in order to accurately calculate an estimated concentration value for the newly recognized substance. In this manner, recognition and measurement of a substance requires prior qualitative (pattern) and quantitative (intensity) calibration using known concentrations of the substance to be recognized.

The apparatus required to accomplish analytical tasks in absorption spectroscopy is well known to analytical chemists [13], but may not be evident to others who do not regularly work in the analytical or research sciences. Basic elements of any system are described in the Figure 9 and include a source of light in the wavelength range of interest, a transparent cell to hold the sample and permit the light to be transmitted through the sample for a specific distance, a detector to measure the amount of light that has been transmitted through the sample and convert this information into numbers, and finally a means to process and interpret the information detected from the sample. The instruments currently in use range from the simple to the sublime.

Simple absorption spectroscopy systems, such as the colorimeter described in Figure 10, have a limited (or single) wavelength range, and very simple fixed computational capabilities built into the instrument. These systems recognize only one substance (or family of substances) and usually require that the samples be processed or chemically altered to yield an indicator color prior to analysis. Systems with a broader range of capabilities, such as the spectrophotometer shown in Figure 11, are designed to permit analysis of a greater amount of information by detecting absorption at several (or many) wavelengths. This is accomplished by either altering the wavelength at the light source and using a fixed detector, or using a broad band light source and then selecting wavelengths for detection after transmission through the sample. In either case, the instrument must mechanically step through a sequence of wavelengths in order to collect information from the entire range of interest. This makes the instrument slow, fragile, and mechanically complicated, none of which are qualities that are suitable for use in field or factory environments for real time/on-line analysis of unaltered flowing samples.

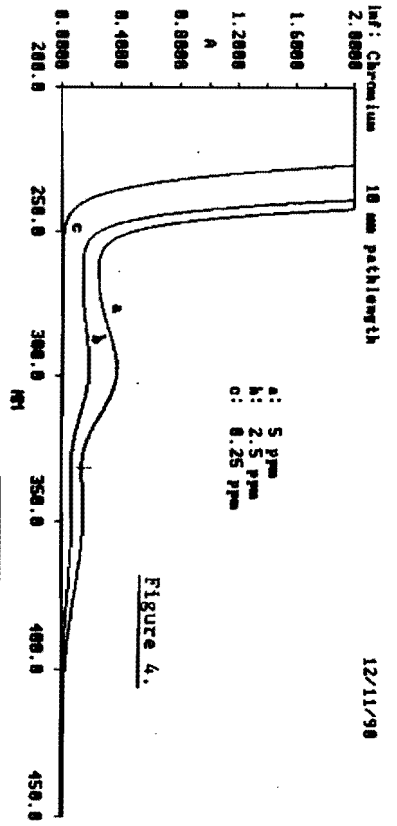

Figure 4.

12/11/90

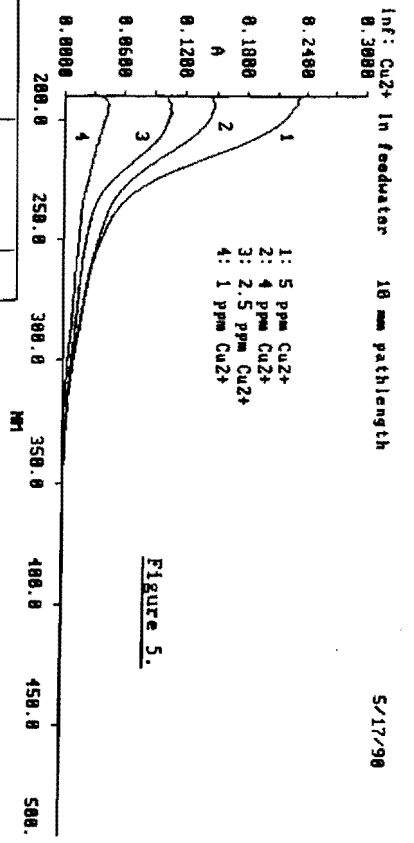

Figure 5.

5/17/90

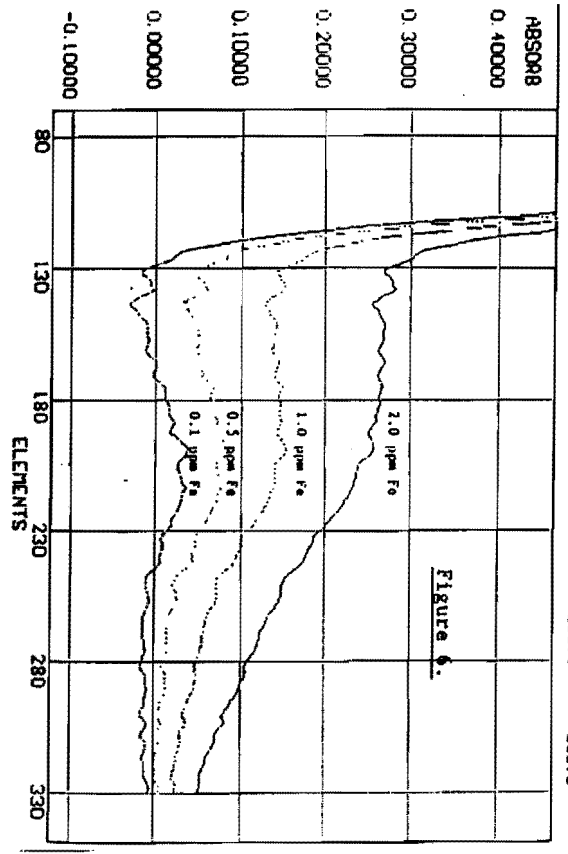

Figure 6.

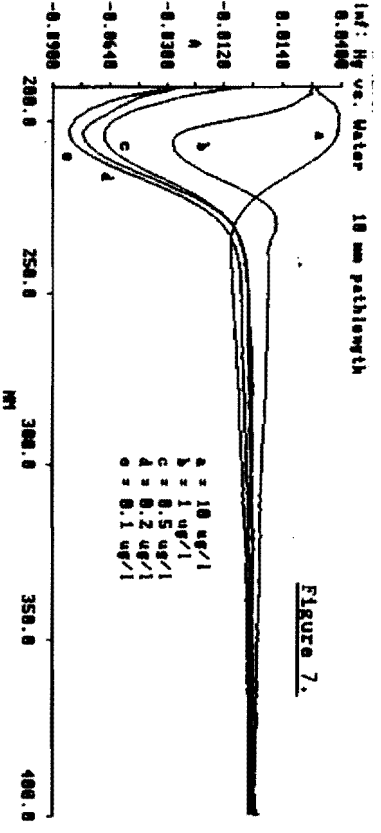

Figure 7.

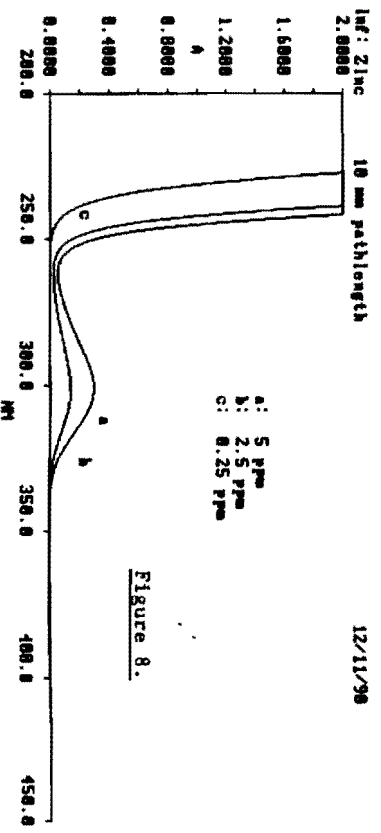

Figure 8.

12/11/90

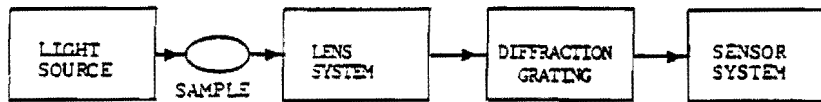

Figure 9. Basic elements of a spectrometer.

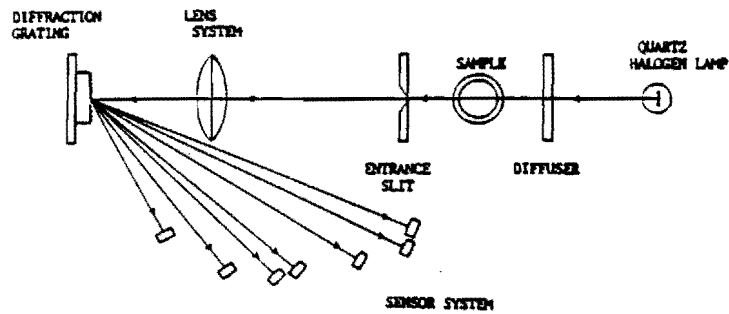

Figure 10. Colorimeter optical diagram.

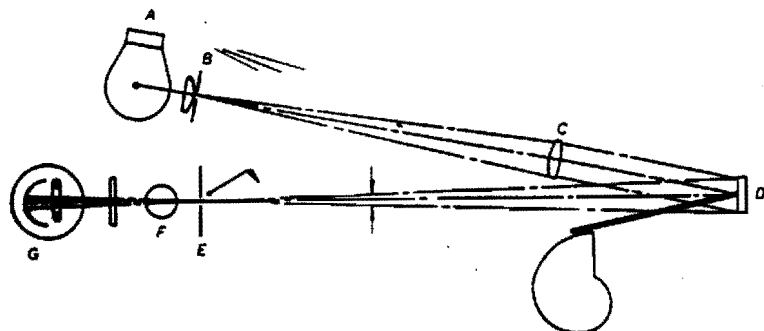

Figure 11. Spectrophotometer with light source (A), diffraction grating (D), and phototube detector (G).

IV. Technology Advances for On-line Absorption Spectroscopy

Several recent developments have made ultraviolet-visible absorption spectroscopy a feasible technology for use in the field and on the factory floor:

* **FIBER OPTICS** permit substantial distance between the analyzer and the substance to be analyzed. The remote analyzer can house a light source, detector, and electronic components. Fiber optic cables convey the source light to an OPTRODE, where the light is transmitted through the sample, then collected and returned to the detector through a companion cable. Optrodes may be immersed in a process tank or flow stream, then removed after the analysis has been performed (Figure 12), or may be permanently located at the sample point for continuous monitoring. These are two types of IN-SITU analysis. Alternatively, a sample line may be connected to a flow through cell containing the optrode (Figure 13). This is ON-LINE analysis.

* **ARRAY DETECTORS** permit a broad wavelength range to be simultaneously detected at discrete intervals. This eliminates the need to create intervals by altering wavelengths at the source or prior to detection. Instead, a broad source can be used and fully detected. An evaluation can be made of wavelengths which contain absorption features relevant for the analysis. Wavelengths and ranges which do not contain information that contribute to the analysis can be ignored, even though the detection will include information from the entire range. A state of the art ultraviolet-visible absorption spectroscopy system such as the BI-800 uses a xenon lamp with an output from 200 nm to 800 nm, and an array detector that segments the detection range into 1024 equal intervals and scans across this entire range. See Figure 14.

* **CHEMOMETRICS** may be the most meaningful advance in technology that makes on-line analysis possible. The relationship between the capability of chemical sensors and the analytical models used to interpret information detected with these sensors is shown in Figure 15. The more specific the sensor is to a particular chemical, the less sophisticated the model required to extract meaningful information. Sensors that detect information for multiple constituents in a complex chemical matrix must rely upon very capable analysis algorithms in order to extract information for a specific chemical constituent. Although one trend in analytical chemistry is toward sensors that are ion or chemical specific, a less publicized trend is toward general purpose analyzers that have very sophisticated data analysis capabilities available within the instrument. These chemometric techniques are used to compare unknowns with calibrated standards and data bases, to perform advanced forms of cluster analysis, and to extract features from unknowns that are used as information in statistical and mathematical models.

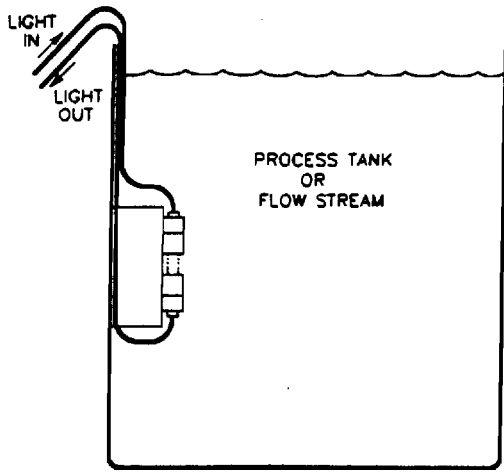

Figure 12. Tank optrode.

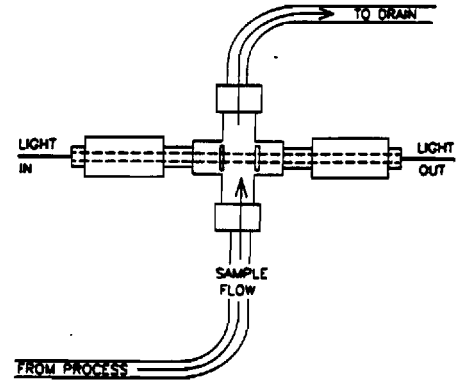

Figure 13. Flow cell optrode.

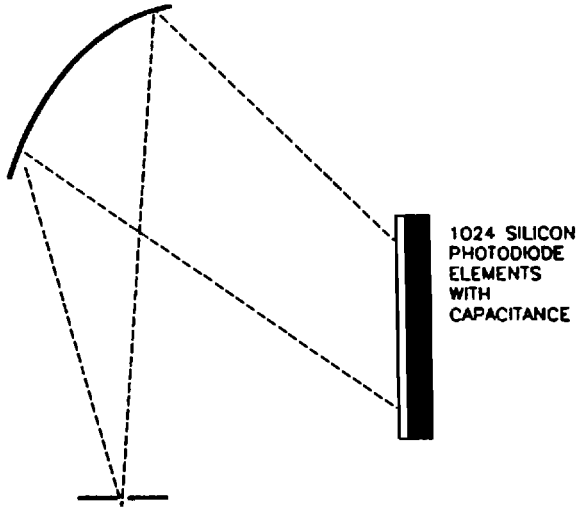

Figure 14. Array detector.

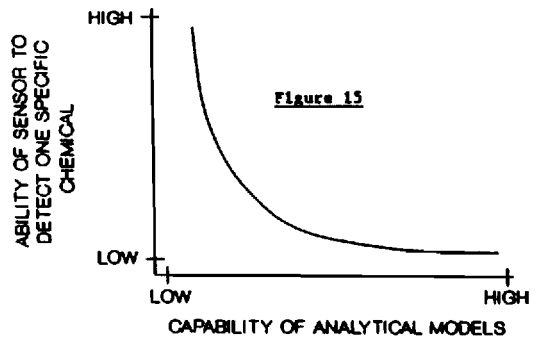

Figure 15

V. Chemometric Analysis of Absorption Spectra

Chemometric techniques are particularly useful for on-line analysis of metals in aqueous media such as wastewater or contaminated groundwater where many different metals can be present together with other chemical constituents, all of which may independently vary in concentration. Overlapping and closely grouped spectra from individual constituents result in a spectral signature for the solution that is a combination of individual elements, as shown in Figure 16. An on-line analysis system must be capable not only of automatically detecting certain significant features for identification of the analytes of interest, it must also be capable of rapidly analyzing these features to arrive at qualitative identification of the analytes and quantitative measurements of their concentrations, and must do so in a chemical matrix that may contain many possible interferants in a variable background.

It is possible to detect the absorption spectra for a water matrix using a specially designed ultraviolet-visible spectrometer equipped with a fiber optic probe and array detector. Chemometric techniques are then used to extract and analyze features in the overall absorption spectra that are specific to the qualitative and quantitative contributions from specific metal analytes. Figure 17 shows three basic steps are involved in the process of using spectra for chemical analysis:

A. **QUANTIFICATION** of absorption spectra for analytes, calibration (learning) sets, and unknowns. This is the process of converting detected spectral information into numerical values that describe the spectra and can be acted on by mathematical and statistical procedures.

B. **PREPROCESSING** of raw data to reduce noise and to optimize the ability of the analysis models to compare known spectra with unknown spectra or to act on specific features for the spectra of a multicomponent solution to permit analysis of individual components.

C. **ANALYSIS** of absorption data to identify individual components and calculate an estimate of their concentration in the solution.

In order for the analyzer to monitor heavy metals with the maximum possible precision, an optimization process as described in Figure 18 is employed, where spectra from several "learning sets" containing known concentrations of the analytes of interest are recorded in the system. Mathematical observations are made of the combination of wavelengths that are likely to provide the best information for analysis of an individual analyte. Spectra from several "test sets" with known analyte values are then detected. The information from the learning and test sets are experimentally processed using different combinations of the available preprocessing and analysis routines in order to arrive at the combination of data points, preprocessing routines and analysis procedures that yield predicted results for the test set samples that are as close as possible to the known values (that is, has the lowest possible average error of estimate for the test set).

This optimization process is sometimes referred to as "calibration", but it is obviously more than just a calibration procedure if the preprocessing and analysis techniques to be used must be chosen. Fortunately, this extensive procedure must only be performed at the start of a monitoring project. Thereafter, only routine calibration using a known standard need be performed.

Some discussion of the most important techniques used in each stage of chemometric analysis may further enlighten the reader.

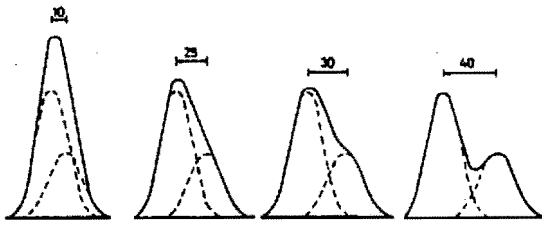

Figure 16. Overlap of spectra.

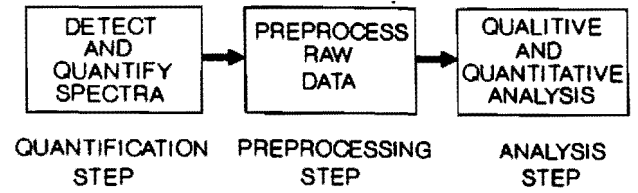

Figure 17. Chemical analysis steps.

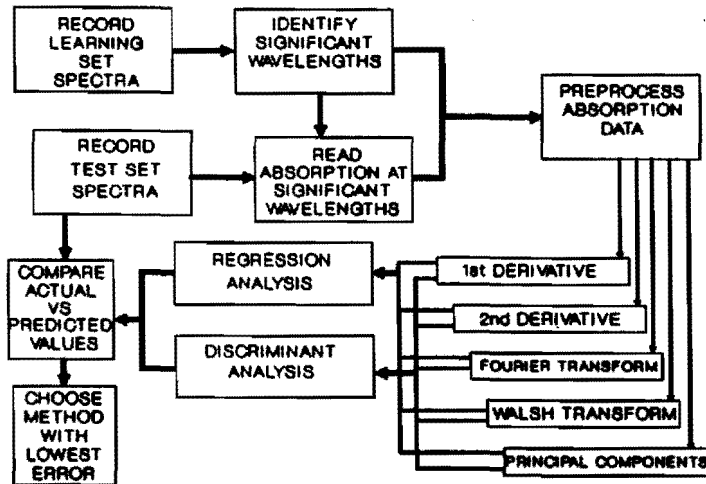

Figure 18. Optimization of analysis models.

A. Quantification of Absorption Spectra

The important features of absorption spectra are its position and intensity, which yield a signature that can be used to define qualitative and quantitative characteristics. These data are a function of the absorption intensities detected at many equally spaced wavelength intervals across a range of wavelengths. Absorption of light is governed by the Beer-Lambert Law that defines the relationship between incident light absorbed by a solution and the molecular concentration of the solution. In simplified form, the Beer-Lambert law may be stated as:

$$A = abc$$

where,

A = The total amount of light absorbed.

a = absorption coefficient defining absorptivity of the media

b = length of the absorption light path

c = concentration of the solution

- Absorption may also be described in terms of a comparison between the intensity of light transmitted through an absorbing substance compared to the light intensity when no absorbing substance is in the light beam:

$$T = (I_t / I_o) \quad \text{and,}$$

$$A = \log (1/T) \quad \text{or,}$$

$$A = -\log (I_o / I_t) = abc$$

where,

T = transmittance

A = absorbance

I_o = Intensity of incident light

I_t = Intensity of transmitted light

The usual case is not one of a single analyte in a perfectly transparent solvent, but one of multiple variable components in a complex chemical matrix. Not only is it possible for each of the components to vary in concentration, but the possibility exists for interactions of components with each other and with the media in which they are contained. Furthermore, there may be a need to identify and measure only one of the components or several of the components. Clearly, this task requires a much more sophisticated form of analysis.

One form of this problem is a mixture in which all of the absorbing components are known. A series of simultaneous equations known as a K-Matrix can be constructed in the form:

$$A = KC$$

where,

A = Absorbance of light = $-\log (I_o / I_t)$

K = ab

a = absorption coefficient

b = path length

C = concentration

Since there are several analytes involved, total absorption will be a function of the sums of all of

the absorbing components based upon the concentrations of the individual components. Equations can be defined for each of m wavelengths, as follows [14]:

$$\begin{aligned} A_1 &= k_{11} c_1 + k_{12} c_2 + \dots k_{1n} c_n \\ A_2 &= k_{21} c_1 + k_{22} c_2 + \dots k_{2n} c_n \\ &\vdots \\ &\vdots \\ &\vdots \\ A_m &= k_{m1} c_1 + k_{m2} c_2 + \dots k_{mn} c_n \end{aligned}$$

Such an analysis requires knowledge of all of the absorbing components in a solution in order to provide a basis for calibration, which is frequently an unrealistic condition to achieve. Therefore, an inverse technique that defines concentration as a function of absorbance has been developed. This P-Matrix approach does not require a knowledge of all of the absorbing components in the solution, but does use a series of simultaneous equations in the form:

$$C = PA$$

where,

$$P = K^{-1}$$

Equations can be defined for each of n analytes, as follows:

$$\begin{aligned} C_1 &= P_{11} A_1 + P_{12} A_2 + \dots P_{1m} A_m \\ C_2 &= P_{21} A_1 + P_{22} A_2 + \dots P_{2m} A_m \\ &\vdots \\ &\vdots \\ &\vdots \\ C_n &= P_{n1} A_1 + P_{n2} A_2 + \dots P_{nm} A_m \end{aligned}$$

B. Preprocessing of Absorption Spectra

In many applications, multiple components are present. Although spectra for multiple components may overlap at one or more points in the absorption band and may be affected by noise or drift, there are several techniques for preprocessing of the spectra to provide mathematical transformation of closely grouped spectra, elimination of noise and adjustment for baseline drift. In addition if features from different spectra are to be compared, it may be helpful to amplify any differences that may exist in order to make meaningful comparison easier. These tasks are commonly accomplished using first or second derivatives, Fourier or Walsh (Hadamard) transformations, or Principal Components analysis. Figure 19 is a graphic example of how the original absorption spectra for molybdate in cooling water was transformed using some of these standard transformation techniques. If two original spectra were very similar, but not identical, examination of the transformed spectra might better reveal their differences. Alternatively, if differences in spectra were the result of noise or drift, comparison of the transformed spectra may reveal similarities not evident in the original spectra.

The technique that appears to be most promising for analysis of individual components in multivariate media is Principal Components Analysis (also known in some applications as Eigenvectors, Hotelling transformations, or Karhunen-Loeve transformations). Principal Components is a

transformation of the coordinate system for a data set based on statistically determined quantities. A simplified example is shown in Figure 20. The purpose of this transformation is to rotate the coordinate system in a way that results in the alignment of information on a fewer number of axes than in the original arrangement. This results in a compression of the variables by allowing those variables that are highly correlated with one another to be treated as a single entity. After Principal Components Analysis, a small set of uncorrelated variables will represent most of information that was in the original set of variables, but will be far easier to use in subsequent analytical models. [15, 16, 17] Typically, 2 to 4 Principal Components account for 85-98% of the variance in the original data. Special techniques are available to assure that the variables that help explain the target analyte are not eliminated if they do not appear among the few variables that explain most of the variation in the original data set.

C. Existing Techniques for Analysis of Absorption Spectra

If calibration information were available for a number of samples of an analyte in a solvent at different concentration levels, parametric techniques can be used to perform an analysis of information for an unknown solution. There are two techniques in particular that are most often used:

1. **REGRESSION ANALYSIS** [18], typically a multiple linear regression since multiple wavelengths are used to characterize each analyte and since multiple analytes are usually being monitored. The regression defines the values of known concentrations of the analyte in terms of the significant variables in the signatures for the analyte, then uses this information to define the best fitting plane for the information using least squares techniques to define each boundary of the plane. The measurements of the variables for the unknown is fit to the plane in order to recognize and assign a predicted value to an unknown concentration of the analyte. Figure 21 is a graphic representation of a three dimensional regression plane.

2. **DISCRIMINANT ANALYSIS** [19, 20], where absorption variables at significant wavelengths from the calibration set are used to organize the information for known concentrations of the analyte into clustered groups, so that linear decision boundaries can be defined to separate the clusters, as shown in Figure 22. An analyte of unknown concentration can be matched with the closest group based on detection of the significant variables. Typically, the unknown is assigned a characteristic or average value of the group to which it has been matched. This is a very useful technique for quality screening, where the sample is to be sorted into defined categories (acceptable / suspect / unacceptable) based on measured comparisons between the samples and the clusters.

D. Emerging Techniques for Analysis of Absorption Spectra

An emerging technique for analysis of multicomponent solutions that does not rely upon functional relationships is the Lattice K-Nearest Neighbor approach. [21] This technique does not require any site specific samples for calibration of the analyzer, but relies upon the analyzer possessing information for a substantial multiple site data base, where many analyte sample values have been organized into the nodes of a lattice network based upon their principal component coordinates. Predicted values for analytes in unknown samples are based upon the relative distances between variable values for the unknown and the nearest neighbors in the lattice. This is graphically represented in Figure 23. A sampling interval is used to establish a window that limits the comparisons to a finite region of the lattice network.

In an advanced version of this technique, processing can be made more efficient by partitioning the lattice into zones based on a sample characteristic that is unrelated to the analyte value, then

testing the sample for this characteristic as a classifier prior to analysis for analyte values. In addition, inductive learning and neural network analysis, while still very experimental, show great promise for more complex applications, especially those that do not lend themselves to simplification through the use of principal components analysis techniques.

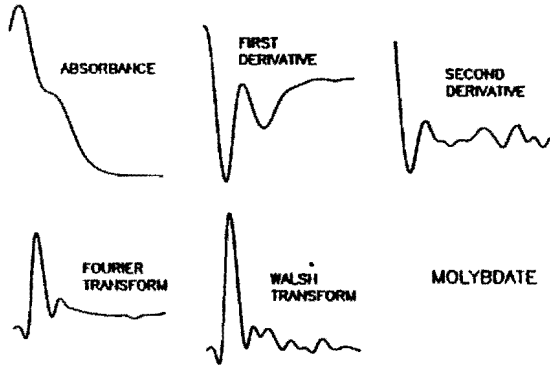

Figure 19. Transformed spectrum for molybdate

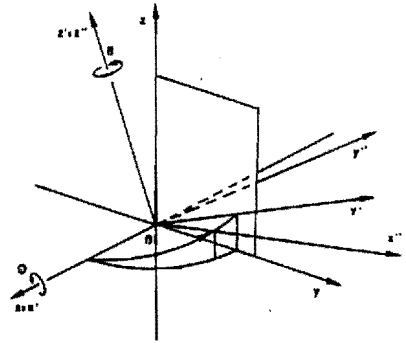

Figure 20. Principal components rotation.

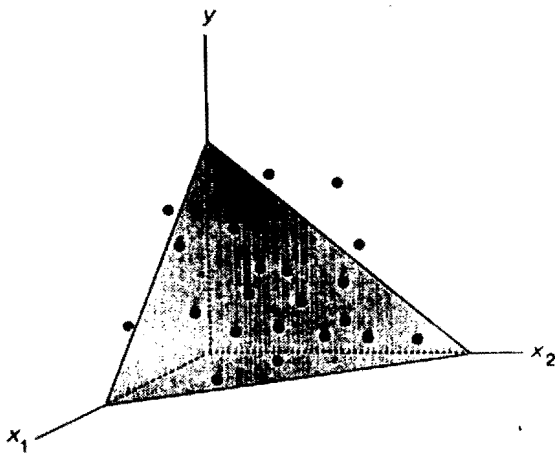

Figure 21. Three dimensional regression plane.

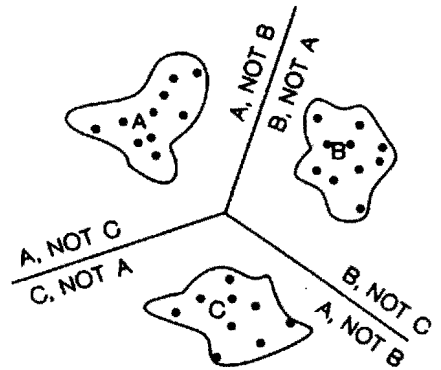

Figure 22. Linear decision boundaries.

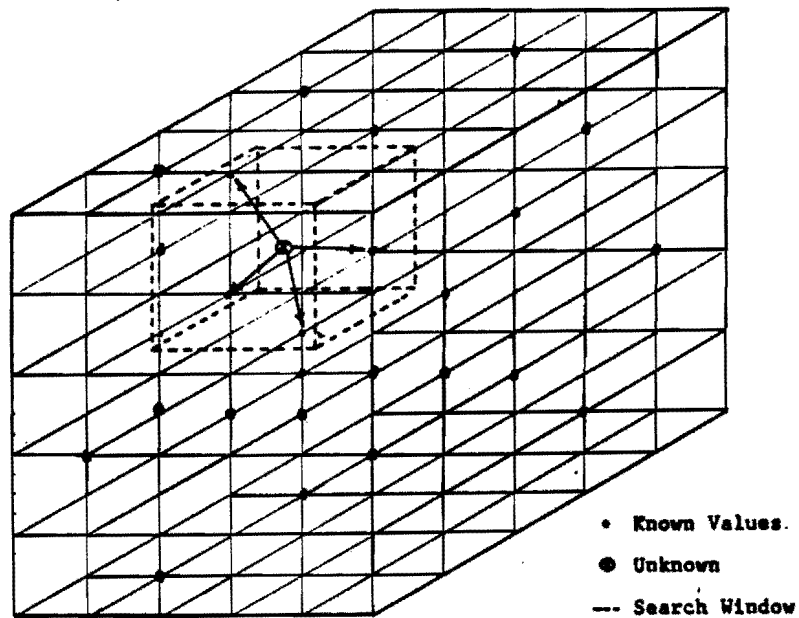

Figure 23. Lattice Arrangement

VI. Application of Chemometrics for Analysis of Heavy Metals

The apparatus and chemometric techniques discussed above have been used in several recent demonstrations for the analysis of heavy metals in multi-component solutions.

A. Iron and Copper in boiler feed water

A demonstration of the ability to identify and measure individual components in a multi-component matrix using chemometric analysis of absorption spectra was performed recently for an electric power utility. The objective was to identify and measure iron and copper in boiler feedwater to measure the efficiency of treatment processes. Spectra for several concentrations of iron were characterized as shown on Figure 24 and for several levels of copper as shown on Figure 25. After spectra had been characterized, a learning set of 15 boiler feedwater samples with concentrations of iron ranging from 0.5 ppm to 10.0 ppm and concentrations of copper ranging from 1.0 ppm to 5.0 ppm were analyzed. Figure 26 shows a plot of the spectra for these 15 learning set samples. A test set was processed using linear regression and discriminant analysis, each with untransformed absorbance values and three transformation techniques (first derivative, Fourier, and Walsh). Results are summarized in Figure 27. In the learning set, discriminant analysis produced consistently superior results for iron and for copper, regardless of the type of preprocessing used. The use of Walsh transformations with discriminant analysis produced the lowest error for either analyte. This same analysis was performed for a test set, where discriminant analysis using Walsh transformations recognized 0.5 ppm iron with an error of 0.13 ppm, and recognized 5.0 ppm copper with an error of 0.007 ppm.

B. Iron in a nutrient solution

Under a recent NASA contract [22], iron was analyzed using absorption spectroscopy in a complex nutrient solution consisting of copper, nitrates, phosphates, calcium, magnesium, sodium, and chlorides. Iron was measured over a range of 0 to 10.0 ppm in a set consisting of 20 samples with randomized backgrounds of the other nutrients. Figure 28 shows the spectra for several of these solutions. An analysis using linear regression without transformations was performed for this set and produced an error from predicted values of less than 0.03 ppm as detailed on Figure 29. Nitrates in nutrient solutions were also successfully analyzed under this contract using absorption spectroscopy, with average errors of under 1.0 ppm over a range of 10.0 to 500.0 ppm.

C. Molybdate in cooling water

Linear regression of untransformed absorbance values were used to measure sodium molybdate concentrations of 1.0 ppm to 2.2 ppm in cooling water that also contains random concentrations of iron, calcium, nitrates, and proprietary treatment formulation chemicals that include azole and polymer complexes. Average errors of less than .126 ppm were obtained.

D. Mercury in industrial wastewater

A recent study for an Air Force base concluded that it was possible to detect the ultraviolet absorption spectra of mercury over a range of 0.0001 ppm to 0.01 ppm in an industrial effluent.

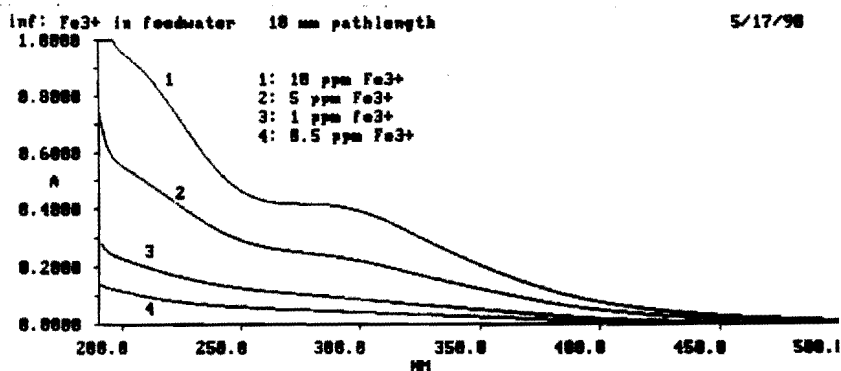

E. Zinc and Chromium in industrial wastewater

Zinc and chromium were analyzed in an industrial wastewater that also contained various levels of arsenic, cadmium, copper, iron, lead, mercury, nickel, silver, cyanide, phenols, chlorides, trichlorethylene, oil, grease, and suspended solids. Despite the fact that the matrix was highly turbid and contained many components, zinc in the range of 0.85 ppm to 3.65 ppm was measured with an error of less than 0.04 ppm while chromium over a range of 0.85 to 4.45 ppm was measured with an error of under 0.03 ppm. These results were achieved with linear regression of untransformed absorbance values.

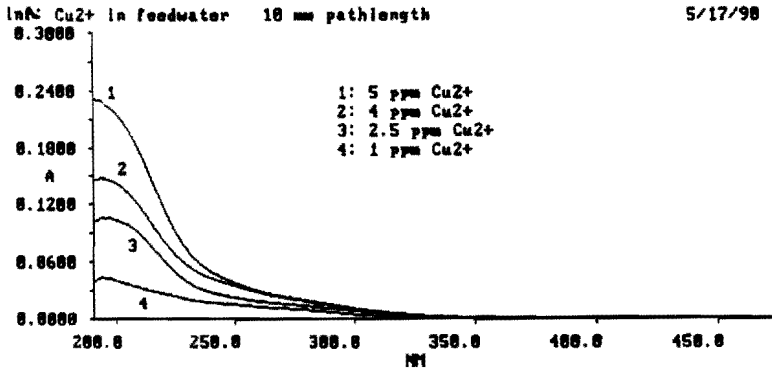

Figure 25. Copper in feedwater.

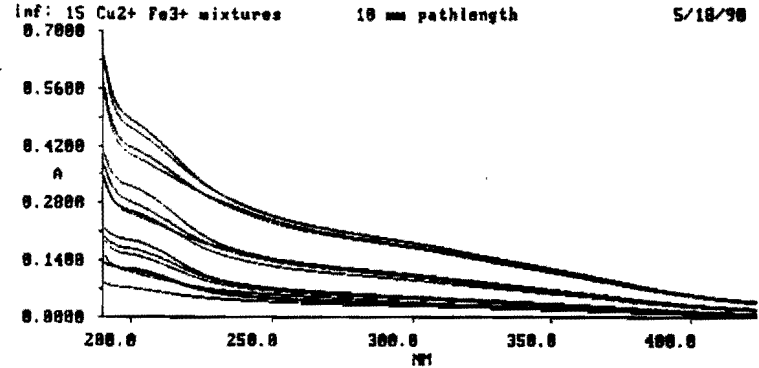

Figure 26. Copper and iron learning set.

Boiler Feedwater Analysis (Copper and Iron)

Learning Set

Regression (standard error of residual, ppm)

	Absorbance	First Derivative	Fourier	Walsh
Fe	0.445	0.411	0.327	0.338
Cu	0.432	0.433	0.395	0.382

Discriminant (pooled standard error, ppm)

	Absorbance	First Derivative	Fourier	Walsh
Fe	0.014	0.072	0.014	0.014
Cu	0.214	0.322	0.208	0.047

Test Set

	Average Value	Discriminant (difference, ppm)	Absorbance	First Derivative	Fourier	Walsh
Fe	0.5	0.13	0.13	0.13	0.13	0.13
Cu	5.0	1.003	2.218	0.007	0.007	0.007

Figure 27.

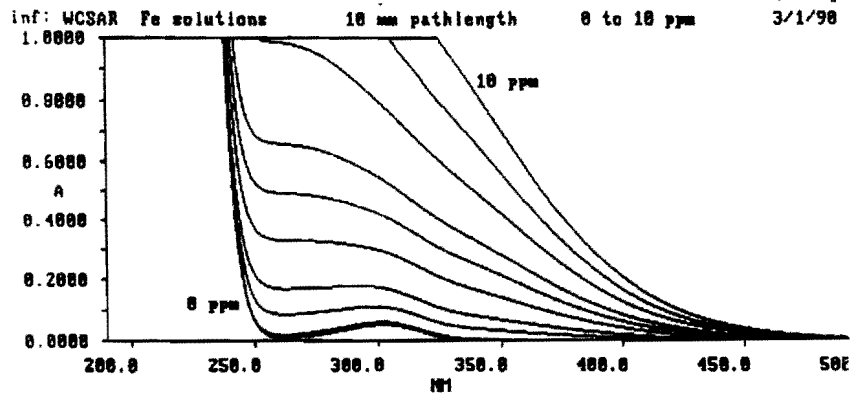

Figure 28. Iron in nutrient solutions

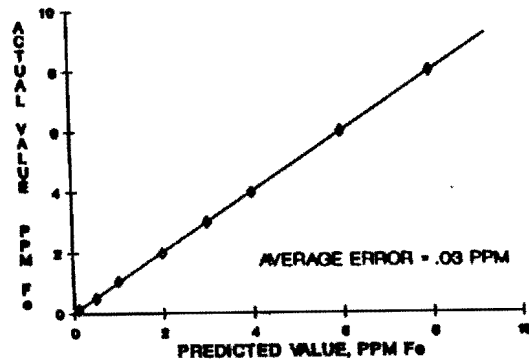

Figure 29. Actual vs. predicted iron values.

VII. Conclusion

Ultraviolet-visible absorption spectroscopy (UVAS) is an emerging technology that is currently being demonstrated for on-line analysis of heavy metals and other chemical substances to monitor water quality in complex multi-component solutions without the need to chemically alter samples prior to analysis.

[NOTE 1]: Ultraviolet-visible absorption spectroscopy (UVAS) for chemical analysis in liquids is a distinct technique that should not be confused with forms of spectroscopy which are performed by observing the presence and intensity of a wavelength peak in a vapor state, or by measuring the intensity of a specific visible wavelength after addition of a reagent. The absorption spectroscopy techniques described in this paper are performed in liquids without any sample processing by recognizing the patterns of absorption at increments over an interval of wavelengths and mathematically determining the contribution from a specific absorbing component to the overall absorption spectra of the liquid.

References:

- [1] Lund, Herbert, editor, "Industrial Pollution Control Handbook", McGraw-Hill, Inc., New York, 1971
- [2] Clean Water Act, 40 CFR 121 to 135 and 403
- [3] Water Pollution Control Federation, "Understanding Hazardous Waste Management", Operations Forum, Volume 8, No. 1, January 1991, pages 22-23
- [4] "National Drinking Water Regulations: A Summary of the Latest Listings", Water Technology, Volume 13, Number 10, October 1990, pages 30-32
- [5] United States Environmental Protection Agency, "Methods for Chemical Analysis of Water and Wastes", publication number EPA-600/4-79-020, Revised March 1983
- [6] Robinson, James, "Atomic Absorption Spectroscopy", Second Edition, Marcel Dekker, Inc., New York, 1975
- [7] Giddings, J. Calvin, "Environmental Contamination by Heavy Metals", Chemistry, Man and Environmental Change, Canfield Press, San Francisco, CA, 1973, pages 331-357
- [8] Smoot, Robert C., et al, "Complex Ions and Coordination Compounds", Chemistry: A Modern Course, Charles E. Merrill Publishing Co., Columbus, OH, 1971, pages 533-545
- [9] Rao, C.N.R., "Basic Concepts and Experimental Methods", Ultraviolet and Visible Spectroscopy Chemical Applications, Second Edition, Plenum Press, New York, 1967, pages 1-12
- [10] Thompson, Clifton, "Absorption of Radiation", Ultraviolet-Visible Absorption Spectroscopy, Willard Grant Press, Boston, Mass., 1974, pages 17-27
- [11] Silverstein, Robert, et al, "Ultraviolet Spectrometry", Spectrometric Identification of Organic Compounds, Fourth Edition, John Wiley & Sons, New York, 1981, pages 305-310
- [12] Hopp, Volfrath, et al, "Inorganic Pigments and Fillers", Handbook of Applied Chemistry, McGraw-Hill, New York, 1983, pages II/8-1 to II/8-23
- [13] Thompson, Clifton, "Instrumentation", *ibid*, pages 29-45
- [14] Thompson, Clifton, "Spectroscopic Applications", *ibid*, pages 47-64
- [15] Jolliffe, I.T., "Principal Component Analysis", Springer-Verlag, New York, 1986
- [16] Zupan, Jure, "Transformations", Algorithms for Chemists, John Wiley & Sons, Chichester, 1989, pages 87-142
- [17] Gonzalez, Rafael, et al, "Image Transforms", Digital Image Processing, Addison-Wesley Publishing Company, Reading, Mass., 1977, pages 38-114
- [18] Hoel, Paul, et al, "Multiple Linear Regression", Basic Statistics, John Wiley & Sons, New York, 1971, pages 252-254
- [19] Goldstein, Matthew, et al, "Discrete Discriminant Analysis", John Wiley & Sons, New York, 1978
- [20] Duda, Richard, et al, "Pattern Classification and Scene Analysis", Wiley-Interscience, New York, 1973, pages 114-121
- [21] Duda, Richard, *ibid*, pages 95-108
- [22] Schlager, Kenneth, Final Report, "Fiber Fluorometry (Spectrometry) for On-Line Chemical Analysis of Nutrient Solutions, NASA Kennedy Space Center Contract Number NAS10-11856