On-Line Monitoring of Water Quality and Plant Nutrients in Space Applications Based on Photodiode Array Spectrometry

Kenneth J. Schlager
Biotronics Technologies, Inc.

The appearance of the ISSN code at the bottom of this page indicates SAE's consent that copies of the paper may be made for personal or internal use of specific clients. This consent is given on the condition, however, that the copier pay a \$5.00 per article copy fee through the Copyright Clearance Center, Inc. Operations Center, 27 Congress St., Salem, MA 01970 for copying beyond that permitted by Sections 107 or 108 of the U.S. Copyright Law. This consent does not extend to other kinds of copying such as copying for general distribution, for advertising or promotional purposes, for creating new collective works, or for resale.

SAE routinely stocks printed papers for a period of three years following date of publication. Direct your orders to SAE Customer Service Department.

To obtain quantity reprint rates, permission to reprint a technical paper or permission to use copyrighted SAE publications in other works, contact the SAE Publications Group.



No part of this publication may be reproduced in any form, in an electronic retrieval system or otherwise, without the prior written permission of the publisher.

ISSN 0148-7191

Copyright 1991 Society of Automotive Engineers, Inc.

Positions and opinions advanced in this paper are those of the author(s) and not necessarily those of SAE. The author is solely responsible for the content of the paper. A process is available by which discussions will be printed with the paper if it is published in SAE transactions. For permission to publish this paper in full or in part, contact the SAE Publications Division.

Persons wishing to submit papers to be considered for presentation or publication through SAE should send the manuscript or a 300 word abstract of a proposed manuscript to: Secretary, Engineering Activity Board, SAE.

Printed in USA

On-Line Monitoring of Water Quality and Plant Nutrients in Space Applications Based on Photodiode Array Spectrometry

Kenneth J. Schlager
Biotronics Technologies, Inc.

ABSTRACT

Significant needs exist for on-line real-time monitoring of water quality and hydroponic plant nutrients in regenerative life support systems. Toxic metals and organic pollutants in recirculated water are more effectively controlled by on-line monitoring. Biomass production of various crops may be enhanced by optimal control of plant nutrients. A new on-line fiber optic spectrometer is in development that uses a combination of ultraviolet-visible absorption measurements in combination with liquid atomic emission spectra to assay a wide variety of chemical compounds and ions in solution. Problems created by interfering, overlapping spectra are solved through the use of pattern recognition methods for multicomponent chemical analysis. This analytical instrument has been successfully applied to the analysis of 15-component plant nutrient solutions.

INTRODUCTION

This paper describes two techniques of spectrometric analysis that allow for the on-line monitoring of water quality parameters and plant nutrients in regenerative life support systems. These techniques are implemented in the form of a photodiode array spectrometer capable of measuring both light absorption of liquids in the ultraviolet-visible region and with the same instrument recording the light emission spectra of these same liquids stimulated by an electric arc excitation.

There is a growing need for on-line monitoring and control in the process industries. On-line control allows for improvements in product quality while retaining limits on the cost of production. Regenerative life support systems can also derive significant benefits from on-line process monitoring particularly in water quality control and hydroponic biomass production systems. Most previous attempts at comprehensive on-line analysis of process fluids have been based on automation of existing "wet chemistry" laboratory procedures. Such automated instrumentation almost always requires the use of the same chemical reagents used in the laboratory. These on-line wet chemistry systems have not proven effective even when limited to the measurement of a few analytical parameters.

A preferred form of process instrumentation would function without the need for consumable chemical reagents basing its operation on physical measurements of the process liquid itself. One possible answer to this instrumentation requirement is a new form of electro-optical spectrometry that has achieved prominence in recent years: near infrared (NIR) spectrometry. NIR satisfies the requirement for an analytical technique based on direct measurement that does not require the use of chemical reagents. NIR spectrometry measures light absorption in the near infrared spectral region. NIR instrumentation has demonstrated its capabilities in the laboratory and in limited on-line application such as moisture measurement during the past decade. It is now being introduced for comprehensive on-line analysis of process fluids in a number of industries.

Unfortunately, NIR spectrometry performs most effectively in a range of chemical concentration, 0.1% - 100.0% by weight or volume, considerably above the level of most water contaminants and plant nutrients. Water contaminants and plant nutrients, both organic and inorganic, are typically in the low parts per million range considerably below the detection limits of NIR instrumentation. This lack of sensitivity is unfortunate since NIR technology has developed in the past decade not only a new form of process instrumentation but also a set of mathematical/statistical algorithms capable of indentifying and quantifying a wide variety of chemical analytes even in complex multicomponent chemical process environments.

Fortunately, however, recent developments under NASA sponsorship have permitted the transfer of the techniques of quantitative analysis originally applied in the near infrared region to another portion of the electromagnetic spectrum, the ultraviolet-visible region, more conducive to the trace level analysis requirements of regenerative life support systems. This paper will describe two spectrometric techniques and their implementation in a hybrid instrument that provides for the on-line analysis of most water quality contaminants and plant nutrients.

Originally, three spectrometric techniques were investigated for applications in plant nutrient analysis:

1. Fluorometry
2. Molecular (Ionic) Absorption Spectrometry
3. Liquid Atomic Emission Spectrometry

Fluorometry was emphasized in early investigations but was found to be the least attractive alternative from an overall cost-effectiveness viewpoint. Molecular absorption spectrometry was successfully applied to six analytes and holds promise for others. Liquid atomic emission spectrometry, a new technique, was not discovered until late in the program but was successfully applied to seven analytes with strong promise for at least three more. A listing of all analytes and related spectrometric techniques is detailed in Table I. This paper will confine its attention to absorption and emission spectrometry.

ULTRAVIOLET-VISIBLE ABSORPTION SPECTROMETRY

Absorption spectrometry is based on Beer's Law which states that light absorption through a liquid (or gas) medium varies with:

1. Absorptivity of the medium - a
2. Path length - b
3. Concentration of medium - c

$$A = abc = -\log(I_o/I_i)$$

I_o - Intensity of absorbed light

I_i - Intensity of incident light

Beer's Law relates absorption to concentration, but it says nothing about the relationship between absorption and molecular structure. The total energy of a molecule is the sum of its electronic energy, its vibrational energy and its rotational energy. Energy absorbed in the ultraviolet region produces changes primarily in the electronic energy of the molecule resulting from transition of the valence electrons in the molecule. Energy absorbed in the near infrared region emphasizes the vibrational energy of the molecule. Electronic transitions in the ultraviolet cause significantly higher absorbance than vibrations in the near infrared. For this reason, the ultraviolet region is the region of choice for trace level nutrient concentrations in CELSS. The near infrared region is better suited to higher levels of chemical concentrations.

Most of the literature on ultraviolet spectrometry relates to organic compounds and the absorption characteristics of chromophoric groups such as ketones, aldehydes and esters. Such compounds are of little interest in nutrient analysis which is characterized by inorganic rather than organic compounds.

Interest here relates to the tendency of some metals such as iron, manganese, titanium, copper and zinc to form large complex ions in aqueous solutions. These complexes are called coordination compounds. Such compounds are formed by a central metal ion or atom surrounded by groups called ligands. The most common centers of coordination are the atoms or ions of the transition metals (iron, copper, zinc, etc.). Common aqueous ligands

Table I
Spectrometric Alternatives

<u>Analyte</u>	<u>Feasible Technique</u>		<u>LAES</u>	<u>Preferred Technique</u>	<u>Status</u>
	<u>Primary Absorbance</u>	<u>Secondary Absorbance</u>			
*Fe	Yes	Yes	Yes	PA	1
*K	No	Yes	Yes	LAES	2
*Mg	No	Yes	Yes	LAES	2
*Ca	No	Yes	Yes	LAES	2
*pH	No	Yes	Yes	SA or LAES	2
*NO ₃	Yes	No	No	PA	1
*H ₂ PO ₄	Yes	Yes	No	SA	2
*SO ₄	Yes	Yes	Yes	SA	2
Na	No	Yes	Yes	LAES	2
Cl	No	Yes	Yes	SA	3
Mn	Yes	Yes	Yes	LAES	3
Cu	Yes	Yes	Yes	LAES	2
Zn	Yes	Yes	Yes	LAES	2
MoO ₄	Yes	Yes	Yes	LAES	3
BO ₃	Yes	Yes	Yes	LAES	3
O ₂	No	No	Yes	LAES	2

Symbology

Preferred Technique

PA-primary absorbance

SA-secondary absorbance

LAES-Liquid Atomic Emission Spectrometry

* - original analyte objective

Status

1. Tested in nutrient solutions
2. Tested in water
3. Not yet tested

are water itself (H_2O), the hydroxyl ion (OH^-) and the chloride ion (Cl^-). An interesting feature of these coordination compounds is that they generate strong spectra in the ultraviolet-visible region. For example, titanium will form a coordination compound with water $[Ti(H_2O)_6]^{+3}$ which strongly absorbs in the visible and in the near ultraviolet as shown in Figure 1. In fact, solutions of the Ti^{+3} ion appear violet in color as a result of the visible absorption pattern.

In CELSS nutrient solutions the following analytes will probably form complexes that generate significant ultraviolet absorbance spectra:

1. Iron
2. Copper
3. Zinc
4. Manganese
5. Molybdenum
6. Nitrogen as $(NO_3)^-$
7. Sulfur as $(SO_4)^{--}$
8. Phosphorous as $(H_2PO_4)^-$

The last three complexes were found to possess significant ultraviolet spectra even though they are not metals. All three of these complexes function as ligands in coordination compounds. The nitrate ion is believed to form a very strong bond with water to form an aquo coordination compound. The other two complexes form strong bonds with the transition metals.

This same theory of coordination compounds (ion complexes) also predicts that the following nutrients will not generate significant ultraviolet spectra since they do not generally form complex ions:

1. Potassium (K)
2. Sodium (Na)
3. Calcium (Ca)
4. Magnesium (Mg)
5. pH

These analytes except for hydrogen are generally referred to as light metals, alkali metals (K, Na) or alkaline earth metals (Ca, Mg). They are not good candidates for primary absorbance in the ultraviolet region.

LIQUID ATOMIC EMISSION SPECTROMETRY (LAES)

LAES is a new variation of an old technology. Atomic spectrometry differs from the technologies previously discussed in its requirement for input energy to form atoms in

the gaseous state. Materials analyzed are generally in the form of solids or solutions in which elements are bonded to other elements. To obtain the atomic form of the element, those bonds must be broken.

The classic source of energy for breaking these bonds was the flame. If a candle wick is impregnated with table salt (sodium chloride), it will emit an intense yellow light. A potassium salt, in contrast, will provide a bluish tinge to the flame. Given an appropriate level of input energy, all of the atomic elements will emit light in the ultraviolet, visible or infrared spectral regions.

Variations in the form of energy input account for the different forms of atomic spectrometry:

1. flame
2. electrothermal (graphite furnace)
3. electric arc
4. electric spark
5. inductively coupled plasma (ICP) (radio frequency field)

There are also variations in the technique used to extract the information from the energized atom:

1. Atomic absorption
-measuring the light absorbed in the energized atom cell
2. Atomic emission
-measuring the light emitted from the energized atom cell
3. Atomic fluorescence
-measuring the fluorescent light emitted from an atom cell

All of the above forms and techniques, however, have one feature in common, the material or solution being analyzed is converted to a gaseous (or plasma) state. Such an approach requires the extraction of a sample from the process stream. Since the interest in this paper is primarily in on-line, as opposed to sampled off-line, analysis, a different form of atomic spectrometry is required.

Liquid atomic emission spectrometry is a new form of atomic spectrometry in which an arc or spark discharge is used to generate an atomic light emission in a liquid medium. The key word here is liquid, since light emission occurs and is detected in the liquid itself and not in a gaseous medium. Although the exact mechanism of this light emission is

still not known, it is believed that a gas plasma is formed within a liquid-contained "pocket". LAES allows for on-line measurement without the need for sampling. This on-line no sampling feature in the liquid medium differentiates it from other modes of atomic spectrometry. Another important although not unique feature of LAES is the multi-element readout provided by an array spectrometer. Such data acquisition allows for a fast near-simultaneous display of a complete atomic spectrum of multiple elements in less than one second of time. The instrumentation for LAES will be described in a later section of this paper.

The implications of LAES to water quality monitoring CELSS nutrient analysis are best understood from the data in Table II. The table indicates that all toxic metals and every plant nutrient element has an observable

atomic wavelength. Some elements such as phosphorous are weak in intensity but possibly still quantifiable. The ultraviolet absorption alternative still exists for phosphate measurement. In the analytical results presented later, a large number of elements are identified and a significant number are quantified to varying degrees of precision.

Aside from NASA applications, LAES, as an on-line atomic spectrometric technique, has tremendous implications for a whole range of industrial applications. A capability for on-line monitoring of a broad range of metals in liquids would have great impact on the metal plating, electronics, steel and environmental control industries to name just a few. There are also significant advantages to LAES because of its speed and convenience in a laboratory environment.

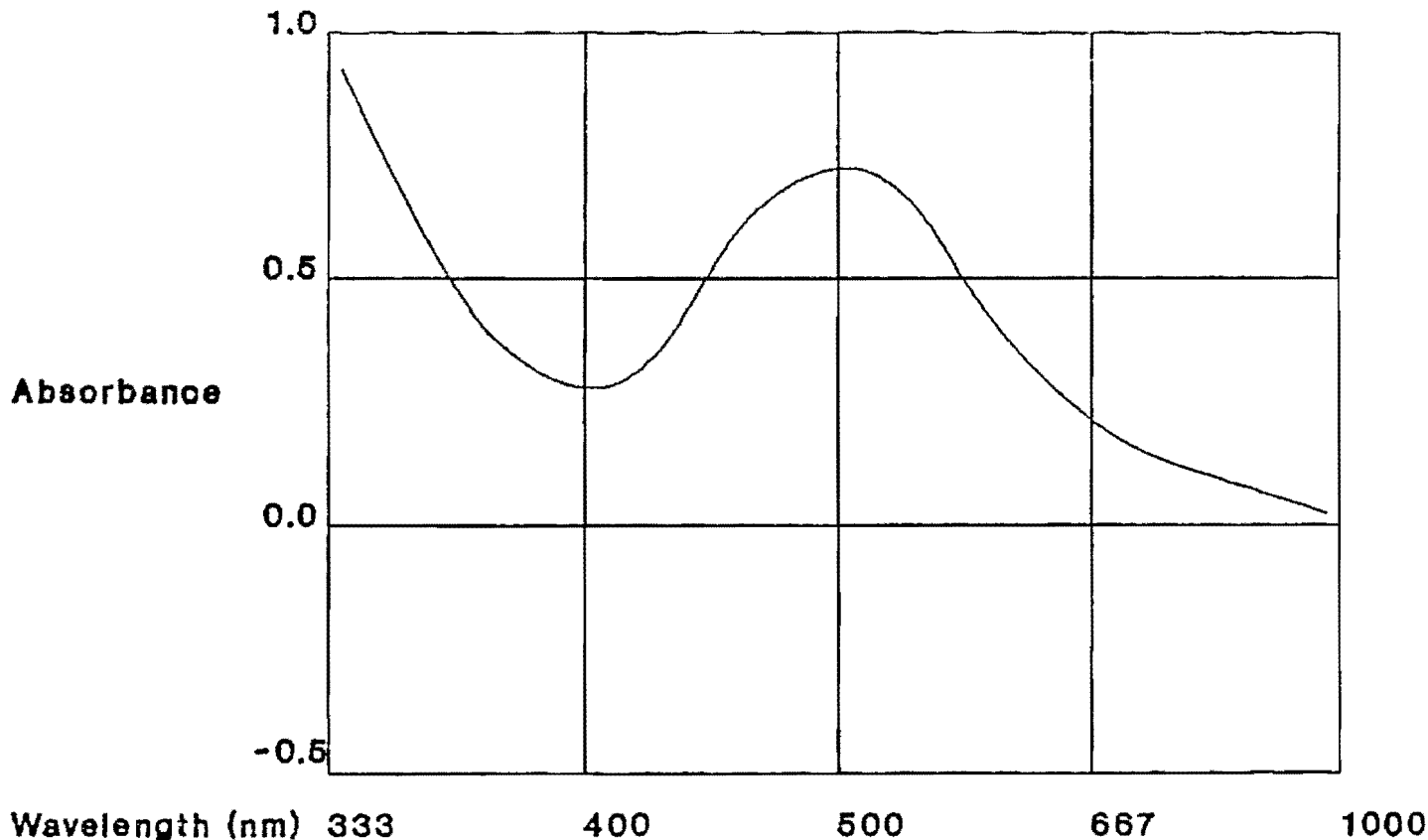

Figure 1
Titanium Coordination Compound in Water $[Ti(H_2O)_6]^{+3}$
H. Hartman, Z. anorg. allg. Chem., 1956, 284, 153.

Table II
Atomic Spectral Lines
for
Nutrient Analysis

<u>Element</u>	<u>Wavelengths (nm)</u>	<u>Intensity</u>
Sodium	589.0, 589.5	2000, 1000
Potassium	766.5, 769.9	1800, 900
Calcium	393.3, 396.8	4200, 2200
Magnesium	285.2, 383.8	6000, 500
Hydrogen	656.3	3000
Iron	373.5	700
Manganese	403.1, 403.3	2060, 1400
Copper	324.7, 521.8	5000, 100
Zinc	636.2	500
Molybdenum	379.8, 386.4	3200, 2800
Oxygen	777.1	1000
Boron	249.8	500
Sulfur	469.5	500
Phosphorous	253.5	80
Nitrogen*	411.0	1000
Chlorine	479.4, 481.0	200

*singly ionized form

Table II
Atomic Spectral Lines
for
Nutrient Analysis

<u>Element</u>	<u>Wavelengths (nm)</u>	<u>Intensity</u>
Sodium	589.0, 589.5	2000, 1000
Potassium	766.5, 769.9	1800, 900
Calcium	393.3, 396.8	4200, 2200
Magnesium	285.2, 383.8	6000, 500
Hydrogen	656.3	3000
Iron	373.5	700
Manganese	403.1, 403.3	2060, 1400
Copper	324.7, 521.8	5000, 100
Zinc	636.2	500
Molybdenum	379.8, 386.4	3200, 2800
Oxygen	777.1	1000
Boron	249.8	500
Sulfur	469.5	500
Phosphorous	253.5	80
Nitrogen*	411.0	1000
Chlorine	479.4, 481.0	200

*singly ionized form

A HYBRID ABSORPTION/EMISSION (HAE) ARRAY ANALYZER

A block diagram of the Array Analyzer in its basic (absorption spectrometry) configuration is shown in Figure 2. A xenon flashlamp light source generates a series of broadband ultraviolet-visible light pulses that are coupled to a fiber optic waveguide (600 micron fused silica core fiber) which transmits this light to an optrode which provides for a light path through the process fluid. Light is partially absorbed in the process stream after which it is returned via fiber cable to the spectrograph where a grating disperses the light in a spectral pattern which is detected by the photodiode array. The array integrates the light over a specified time period and then serially transmits these measurements to the microcomputer through an interface board - typically a series of 10-50 such scans. The microcomputer processes this data in accordance with a predetermined set of algorithms to determine the chemical composition of the process fluid. An

integration time of 0.1 second is typical, so that a series of scans would take place in a period of 1-5 seconds. In CELSS application, this analyzer would be programmed to scan on a periodic basis perhaps every 1 to 5 minutes depending on the dynamics of the process.

A second block diagram of the HAE Array Analyzer in an atomic emission configuration is provided in Figure 4. The light source and transmit cable are not used. Emitted light is transmitted back to the spectrograph as in the basic configuration. In the experimental configuration shown in Figure 4 a simple beaker configuration was used to perform the analyses. In an on-line version an atom cell will be designed to integrate with the present optrode for LAES operation. A possible design arrangement for such an optrode/atom cell is shown in Figure 5.

An important point here is that this same HAE Array Analyzer will provide for dual operations in either the absorption or the emission mode. The analyzer will be programmable from the keyboard to provide variable time interval sequences in either mode.

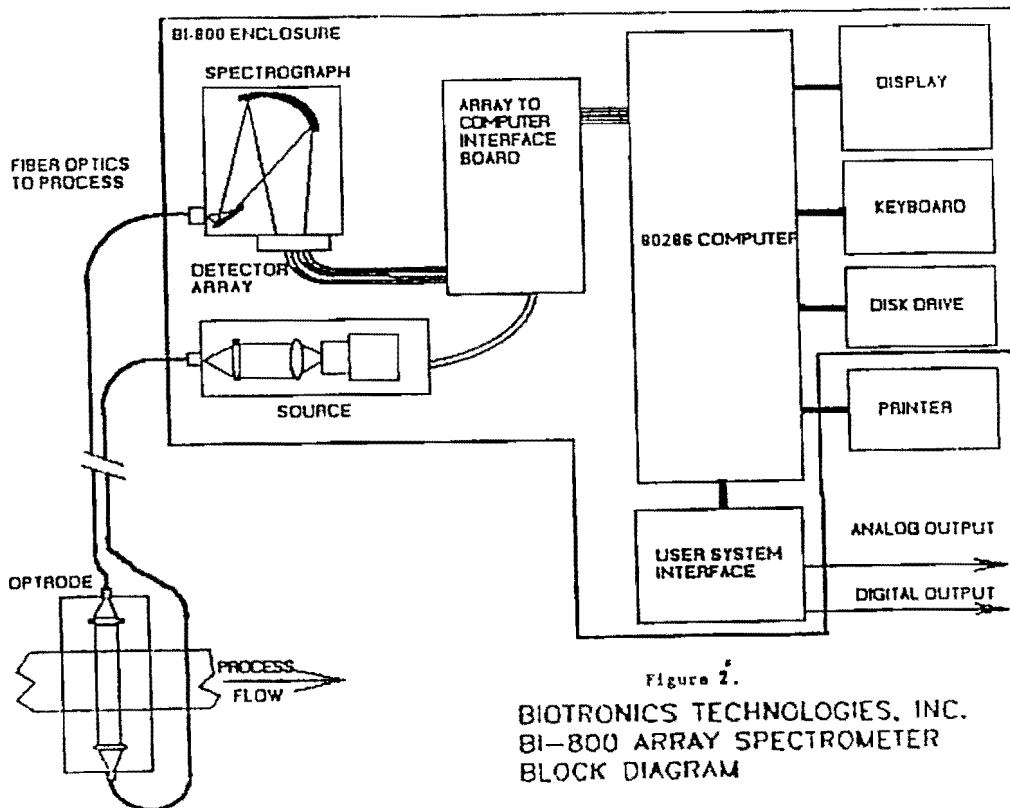
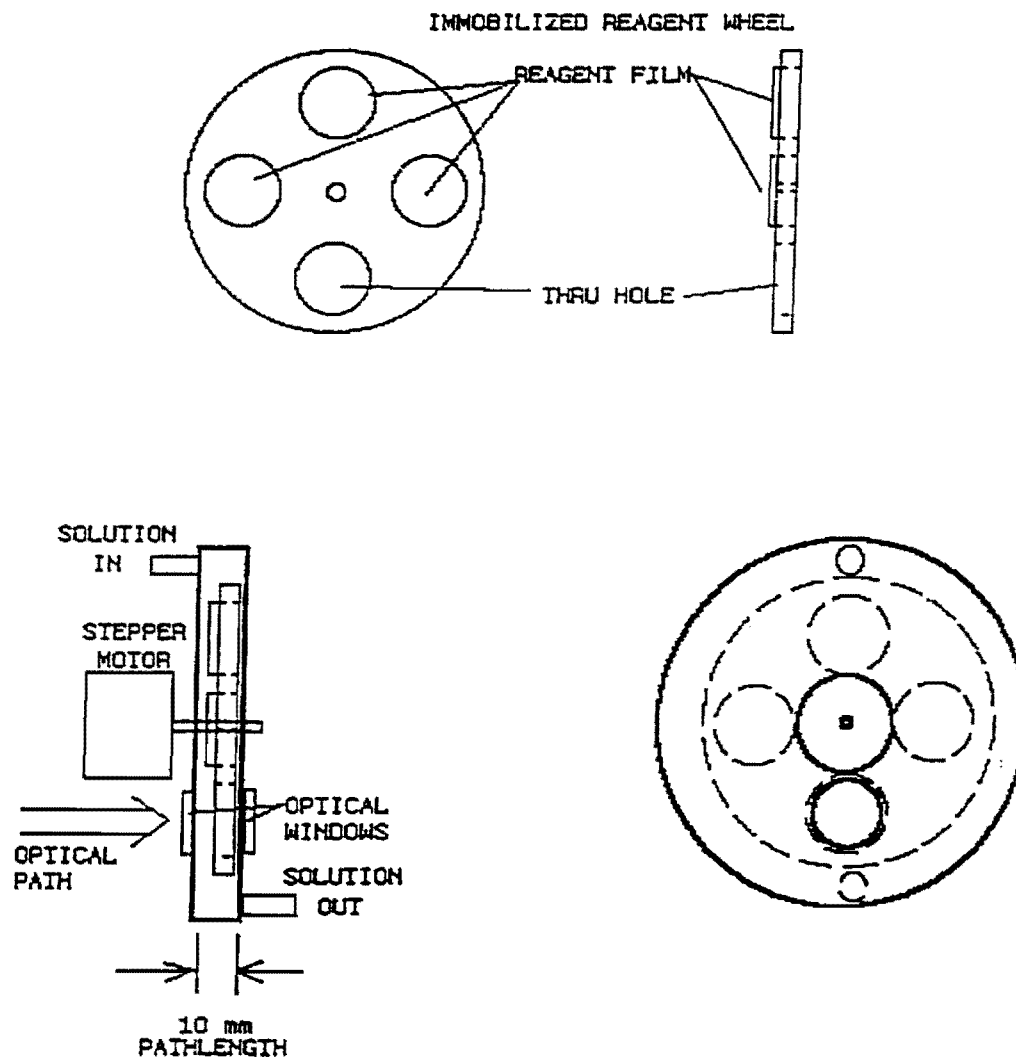

Figure 2.

BIOTRONICS TECHNOLOGIES, INC.
BI-800 ARRAY SPECTROMETER
BLOCK DIAGRAM

Figure 3
IMMOBILIZED REAGENT OPTRODE



BIOTRONICS TECHNOLOGIES, INC.

4-12-80

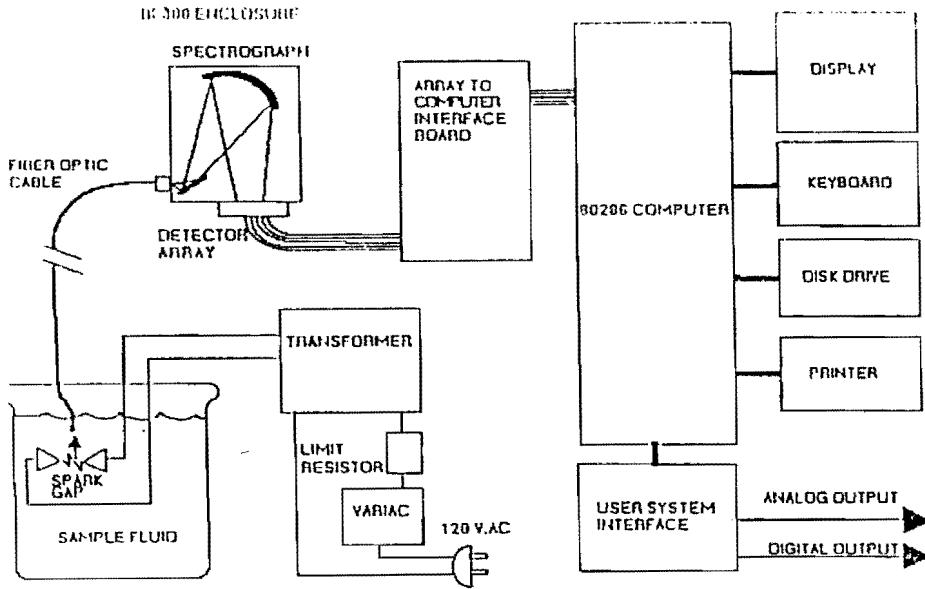

Figure 4.
 BIOTRONICS TECHNOLOGIES, INC. 7-18-90
 ATOMIC EMISSION /
 BI-800 ARRAY SPECTROMETER
 BLOCK DIAGRAM
 A-700-0104

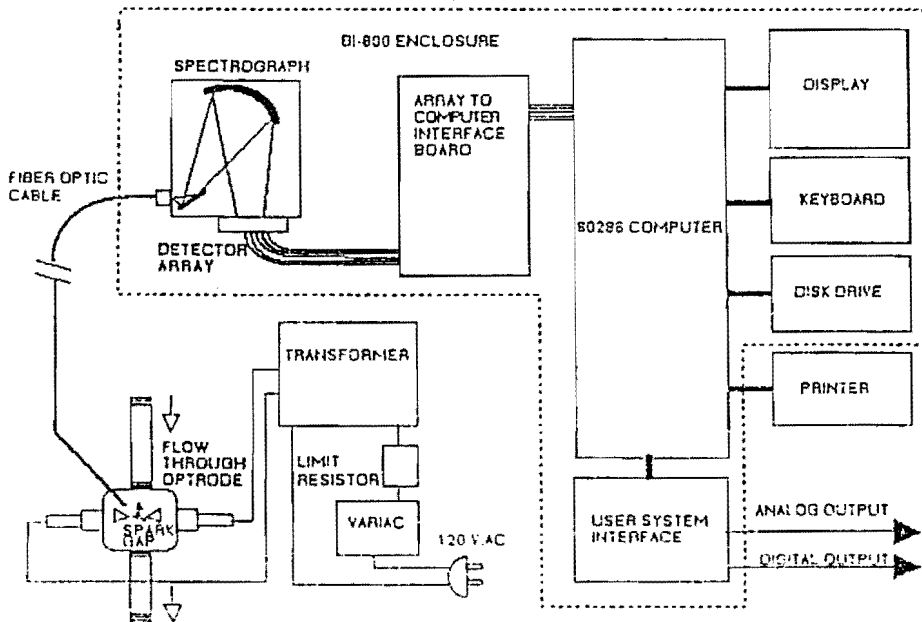

Figure 5.
 BIOTRONICS TECHNOLOGIES, INC. 7-18-90
 ATOMIC EMISSION /
 BI-800 ARRAY SPECTROMETER
 WITH OPTRODE BLOCK DIAGRAM
 A-700-0104

CHELATE CHEMISTRY, SECONDARY ABSORBANCE AND IMMOBILIZATION TECHNIQUES

Inorganic ions in solution can sometimes form complexes with other chemical entities that result in an absorption spectrum which varies in proportion to the concentration of the analyte. These complex ions may form in two different ways:

1. **INORGANIC REAGENT** - A solvent such as hydrochloric acid will often create complex ion structures with strong absorption spectra.

2. **ORGANIC LIGANDS** - In the same way that primary absorbance spectra result from complex ion formations in water, introduction of other potential ligands will generate new coordination compounds with their own spectral patterns. These organic compounds are designated as chelate chemicals.

The first of the above is not practical in an on-line situation since the use of solvent reagents severely complicates such measurements. Chelate chemicals, however, if they involve reversible chemical reactions, can often be immobilized on substrate material that is suitable for inclusion in a fiber optic probe. Use of chelate chemicals to induce absorbance is usually referred to as secondary absorbance spectrometry as opposed to primary where no reagents are required.

Research in this area involved a three-step process:

1. The search for suitable chelate reagents
2. Immobilization of these reagents on suitable substrate material
3. Testing of these reagent strips on-line to determine their sensitivity and stability

CHELATE CANDIDATE EVALUATION - The search for suitable chelate reagents was greatly influenced by previous experience with fluorescent chelates. Chelates are commonly used to produce fluorescence in combination with inorganic ions. Guilbault [Gui 73] provided an extensive catalog of chelate references. This catalog was updated with a computerized literature search.

The following are some of the chelates investigated for the analytes noted:

1. 8-hydroxylquinoline
magnesium, potassium, calcium
2. Calcein
calcium
3. HOPSA
pH
4. Congo Red
pH
5. Zinc uranyl acetate
sodium, potassium
6. Al-Morin
phosphate
7. Th-Morin
sulfate
8. Valinomycin
potassium
9. DEDTC (diethyldithiocarbamate)
iron, copper, calcium and sulfate

The most successful of the above chelate candidates were 8-hydroxylquinoline (magnesium), Congo Red (pH) and DEDTC (iron, copper, calcium and sulfate). Time limitations prevented extensive evaluation of Al-Morin and Th-Morin although past experience with these chelates has been very favorable, and it is believed that they would be quite suitable for phosphate and sulfate measurement.

Interestingly, potassium, calcium and sodium did not significantly interfere with measurement of magnesium with 8-hydroxylquinoline since magnesium is about 100 times more sensitive than the other three analytes to this chelate chemical.

IMMOBILIZATION TECHNIQUE - After extensive experimentation, the immobilization technique used was a variant of that used by Jones and Porter in their measurement of pH using Congo Red [Jon 88]. A nitrocellulose (mixed cellulose ester material) was used in place of the cellulose film used by Jones and Porter.

Twenty-five mm diameter 0.45 or 0.8 micron mixed cellulose ester filters were collapsed onto a glass microscope slide with acetone vapor using a Quickfix apparatus.

The slide was then treated for twelve hours at 22°C with 0.1M sodium hydroxide (which activates the ester). After washing in a 1:1 (v/v) solution of 0.025% (w/v) potassium carbonate, the membranes were transferred to saturated solutions of each agent (e.g. 8-hydroxylquinoline) made up in the wash buffer previously described.

After heating to 100°C, the membranes were left for at least twelve hours at 22°C prior to washing and use.

In off-line testing, these membranes were attached to cuvettes (test tubes) using various adhesives. In on-line testing the membranes were bound to the optrode windows as shown in Figure 3 using optically clear epoxy adhesives. These epoxy adhesives have been previously used with great success by Biotronics in its fiber optic on-line process analyzers.

ANALYTICAL TEST RESULTS

The results of testing and evaluation of the various nutrient analytes will be presented first for ultraviolet-visible absorption spectrometry and then for the new Liquid Atomic Emission Spectrometry (LAES). Graphic presentations on individual analytes will be provided along with comprehensive analyses of nutrient solutions.

ABSORPTION SPECTROMETRY - ANALYTICAL RESULTS - Six different nutrient analytes were successfully measured with primary and/or secondary absorption spectrometry:

1. Nitrogen (nitrate) (NO_3^-) - primary
2. Iron (Fe^{+++}) - primary and secondary
3. Copper (Cu^{++}) - primary and secondary
4. Magnesium (Mg^{++}) - secondary
5. pH (H^+) - secondary
6. Sulfur (sulfate) (SO_4^{--}) - secondary

Nitrate and iron were tested in multicomponent nutrient solutions with randomized values of other analytes. The other analytes were tested in water.

Nitrate Measurement (Primary) - Nitrate spectra in nutrient solutions are illustrated in Figure 6. The graphs indicate the robust nature of the nitrate ultraviolet spectral

response. In the 280 nm region a change of 500 ppm results in an absorbance increase of 0.150 (150 milliabsorbance units), a very substantial response.

After preliminary analysis of nitrates in water solutions, two series of tests were conducted in nutrient solutions, one with ten (10) sample solutions and the second with thirty (30) sample solutions. Accuracies of 1.0 and 0.88 ppm were respectively achieved in the two test sequences over a 0 to 500 ppm range. The accuracy of the final 30-sample test (0.88 ppm) was particularly remarkable since the other nutrients were randomized in value to simulate a CELSS nutrient environment. In this analysis, a first derivative spectral set was used at three different wavelengths:

1. 240 nm
2. 245 nm
3. 310 nm

Four samples were used in the test set with the following results:

<u>Actual Value</u>	<u>Predicted Value</u>	<u>Residual</u>
50.00	50.47	0.47
100.00	101.61	1.61
150.00	149.98	0.02
250.00	249.45	0.55

Average Residual 0.88 ppm

Nitrate testing was used as an early benchmark in this development to not only demonstrate the measurement of nitrate itself but also to verify the feasibility of the on-line reagentless spectrometric approach to nutrient analysis. The accurate results would seem to indicate the accomplishment of this goal.

Iron Measurement (Primary) - Iron spectra in nutrient solutions are illustrated in Figure 7. As a transition element, iron forms strong complex ions with both the hydroxyl ion and water. Iron exhibits strong absorbance spectra even in the 0-10 ppm range. In fact, iron spectral measurement is possible even in the fractional ppm range as shown in Figure 8. These latter spectra were measured on the Hybrid Absorption/Emission (HAE) Array Analyzer and are indicative of the sensitivity of this instrument.

Iron analysis in nutrient solutions followed the nitrate test procedure just described above with initial tests in water followed by two test series in nutrient

solutions of sample sizes of 10 and 30. Accuracy levels of 0.03 ppm were achieved in both series of nutrient tests over a range of 0-10 ppm. In the second series (30 samples), the other nutrient values were randomized including nitrate with its strong ultraviolet absorbance spectrum. Although iron as a nutrient can also be measured using secondary absorbance or atomic emission, primary absorbance measurements will always be available as a sensitive and accurate alternative. Secondary absorbance measurement of iron is covered under the DEDTC reagent section.

Copper Measurement (Primary) - Copper is another transition element that forms coordination compounds (complex ions) in water. Such compounds typically exhibit strong ultraviolet absorbance spectra. Copper spectra generated in the 1-5 ppm range are shown in Figure 9. Although the concentration range here is higher than the expected CELSS range of 0.012-0.127 ppm, this range could be extended with a longer path length. The 1 ppm absorbance level is now at 0.040 absorbance units indicating a potential sensitivity of about 0.05 ppm with a path length of 10mm. Extensions to a 50 mm path length (about 2 inches) would improve sensitivity to 0.01 ppm - the level required for CELSS. Since copper was not one of the original analyte objectives, it was not pursued to the extent of nutrient analysis. Like iron, it also has analytical alternatives in both secondary absorbance and atomic emission.

Magnesium Measurements (Secondary) - As an alkaline earth metal, magnesium does not readily form complex ions in water and does not therefore generate a significant ultraviolet spectrum. The atomic emission alternative was not discovered until later in the development program, so that the primary spectrometric alternative at that time appeared to be the use of immobilized reagents to generate secondary absorbance. Although a number of possible reagents were initially considered, success was achieved with 8-Hydroxyquinoline.

8-Hydroxyquinoline is a chelate chemical that combines with magnesium, some alkali metals (sodium, potassium) and other alkaline earth metals (calcium) to form fluorescent complexes. Since absorbance of light is necessary to create fluorescence, this chelate chemical complex also has an ultraviolet

absorbance spectrum that is sensitive to the chemical concentration of magnesium. This sensitivity is clearly illustrated in Figure 10. Spectra in Figure 10 result from the interaction of magnesium ion concentrations with 8-Hydroxyquinoline, immobilized on a cellulose ester (nitrocellulose) film attached to an optrode window. Graphical notations in the plot indicate that in the CELSS operating range of magnesium (12-30 ppm), a direct measurement is available of magnesium concentration. Interference in this special window in the sensor optrode is minimal since other analytes do not react significantly with this reagent.

The most likely interferents are calcium, sodium and potassium, but these analytes affect absorbance with a sensitivity that is about 2 orders of magnitude less than magnesium, so that effectively magnesium concentration measurement is virtually interference free. The strength of these signals is noteworthy. As magnesium ion concentration changes from 30 ppm to 0 ppm, the absorbance value changes from 239 mau (milliabsorbance units) to 206 mau, a significant change indeed.

The example of magnesium supports the general theory that the secondary absorbance alternative is real, and that, given a suitable chelate chemical specific to a given reagent, on-line secondary absorbance measurements are feasible. The question remaining relates to the stability of the immobilized reagent over long periods of time. Although magnesium tests were conducted over a period of 5-6 weeks on this project, the long term stability of each immobilized reagent is still an unknown.

A major factor in the future of magnesium measurement is the atomic emission alternative. On-line measurement of magnesium may be feasible without any reagents based on atomic emission. These emission test results are discussed later in this section.

pH Measurement (Secondary) - Although pH is currently measurable on-line using ion specific electrodes, a pH measurement as an integral part of the spectrometric package is highly desirable and was listed as one of the analyte objectives in this development. The specified range is from 4.0 to 8.0.

Since the hydrogen ion does not generate a native ultraviolet absorbance, a secondary

X: n500; absc 500.0- 190.0; pts 311; int 1.00; ord 0.0031-5.0000; A
 Inf: WCSAR N solutions 10 mm pathlength 0 to 500 ppm 3/5/98

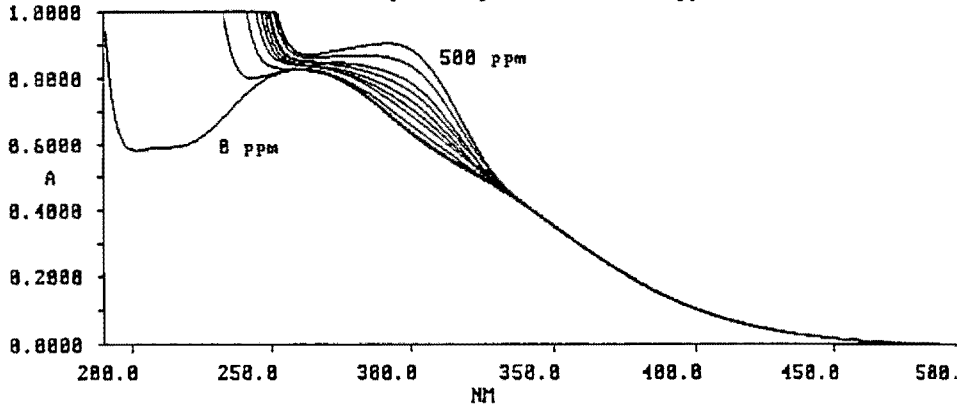

FIGURE 6
 Nitrate Spectra in Nutrient Solutions

X: B6fa; absc 500.0- 190.0; pts 311; int 1.00; ord 0.0051-5.2746; A
 Inf: WCSAR Fe solutions 10 mm pathlength 0 to 10 ppm 3/1/98

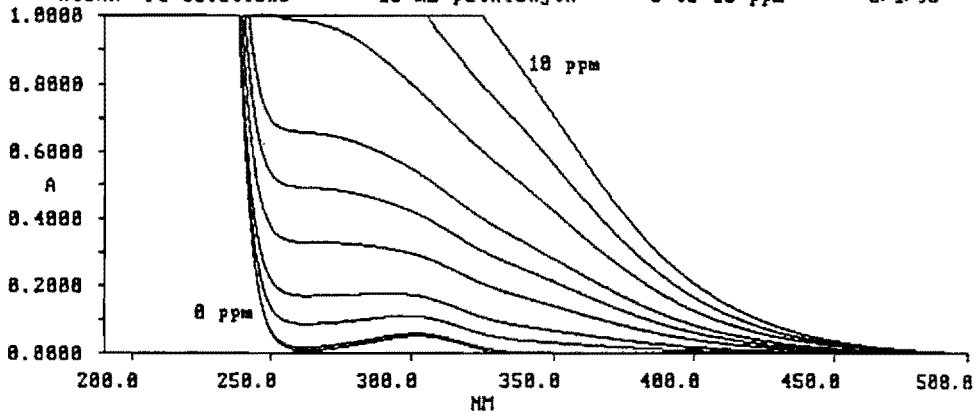

FIGURE 7
 Iron Spectra in Nutrient Solutions

immobilized reagent approach to on-line spectrometric measurement is necessary. A number of examples of fiber optic secondary pH measurement have been published in the literature [Zhu 84] [Jon 88]. Only one, however, provided a fast response and covered the specified range [Jon 88]. In this implementation, the immobilized reagent was a naphthalenesulfonic acid (also known as "Congo Red"). The Congo Red reagent was immobilized in the same nitrocellulose material used for 8-hydroxyquinoline in the magnesium measurement. Absorption for pH occurred in the visible range rather than the ultraviolet region characteristic of 8-OH-Q and magnesium.

DEDTC - A MULTIPLE-ANALYTE REAGENT - A distinct disadvantage of the secondary absorbance approach to nutrient analysis is the potential need for a different reagent for each analyte. While primary absorbance measurements can be performed with a single window in an optrode, each reagent, as shown in Figure 3, will require a separate window. With the potential for 15 separate nutrient measurements, such an approach becomes difficult if not untenable. It is natural, therefore, to search for a multiple analyte reagent that will produce a number of different spectra for each reagent. Such a reagent was found in DEDTC [Otto 85].

DEDTC does provide distinct spectra for a number of analytes. Unfortunately, most of these analytes are transition metals that also exhibit primary absorbance spectra and have no need for immobilized reagents. Iron and copper are in this latter category. Other DEDTC candidates are metal ions that are not used as nutrients in CELSS.

One more CELSS analyte was revealed, however, in the DEDTC spectra: sulfate. Although sulfate generates an ultraviolet spectrum, it tends to be overshadowed by nitrate. Use of DEDTC provides a means of measuring sulfate which otherwise is difficult to measure in nutrient solutions. The secondary spectral plot of sulfate concentrations is shown in Figure 11.

LIQUID ATOMIC EMISSION SPECTROMETRY (LAES) - ANALYTICAL RESULTS

The discovery of LAES during the latter stages of this development project was truly the most important result of the entire program. Although the original analyte objectives probably could have been achieved without LAES using primary and secondary absorption spectrometry, LAES greatly simplified the measurement of some analytes and made some other analytes not part of the original analyte objectives readily measurable. LAES also opened up a whole new horizon of possibilities for both NASA and applications in the industrial marketplace.

Despite the late entry of LAES, an extensive series of measurements was carried on that embraced essentially all of the CELSS nutrients. For the sake of brevity, a quick summary of LAES spectral measurements will be provided followed by a closing discussion. Although a wide range of analytes were investigated with LAES, primary emphasis was placed on analytes that were part of the original project objectives such as potassium and calcium, not easily measured with absorbance techniques. All spectra were collected using the Hybrid Absorption/Emission Array Analyzer in the LAES configuration shown in Figure 4.

INDIVIDUAL ATOMIC SPECTRA - Individual atomic spectra were scanned for a number of elements of interest in aqueous solutions. Varying levels of element concentrations were tested to provide semiquantitative measures of element intensities. Sodium, magnesium, calcium, potassium, copper, zinc, hydrogen and oxygen were all tested in this manner. Two of these spectra for sodium and oxygen are illustrated in Figures 14 and 15.

NUTRIENT SOLUTIONS - University of Wisconsin (WCSAR) nutrient solutions were scanned with LAES to illustrate system sensitivity and to identify some of the elements in Figures 14 & 15. No attempt was made to assign elements to each peak. Calcium, copper, zinc, hydrogen, sulfur, magnesium,

X: Qh20; absc 600.0- 190.0; pts 411; int 1.00; ord 0.0144-6.0000; A
 inf: Mg2+ (0.45 um 8-OH-Q film) 10 mm pathlength 5/25/90

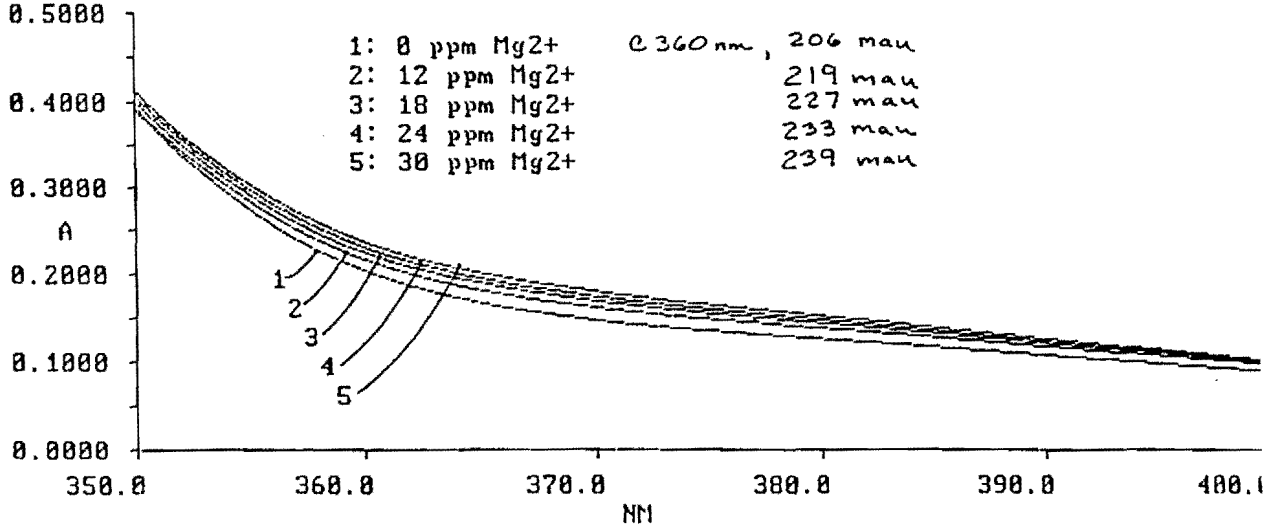

Figure 10
 Magnesium Spectra

Y: sd21_4; absc 500.0- 190.0; pts 311; int 1.00; ord 0.0464-5.0000; A
 inf: S DEDTC 0.45 um film 10 mm pathlength 5/31/90

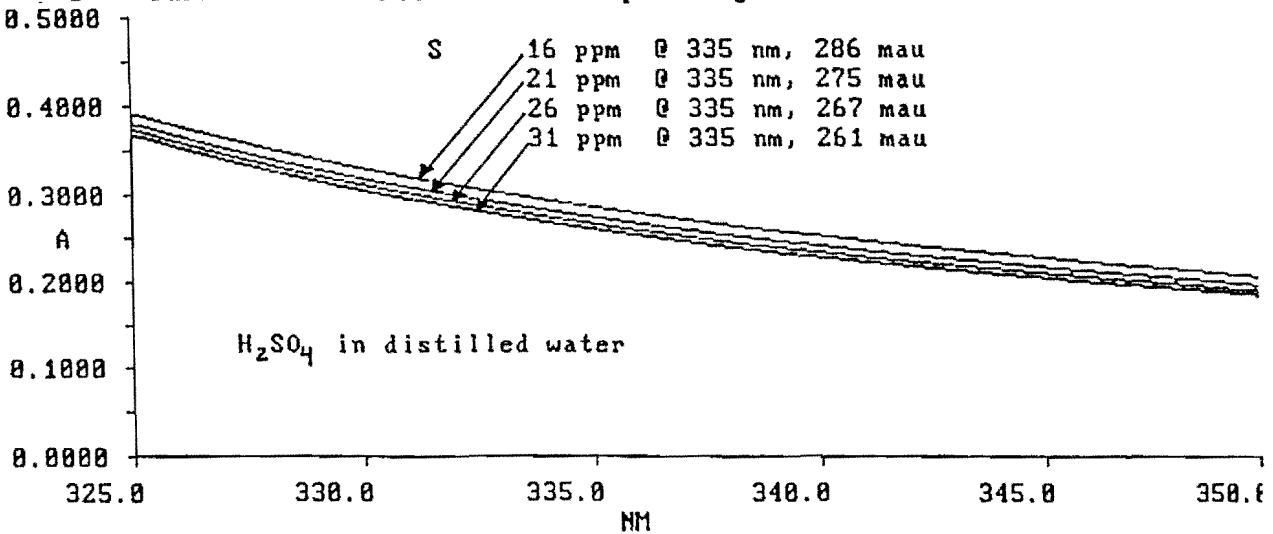

Figure 11
 Sulfate Spectra

FILE 0: Standard

FILE 3: none

FILE 1: c:\tc\800su3\aedu

FILE 4: c:\tc\800su3\aedunahi

FILE 2: c:\tc\800su3\aeduna

Figure 12 Atomic Emission Spectra Sodium

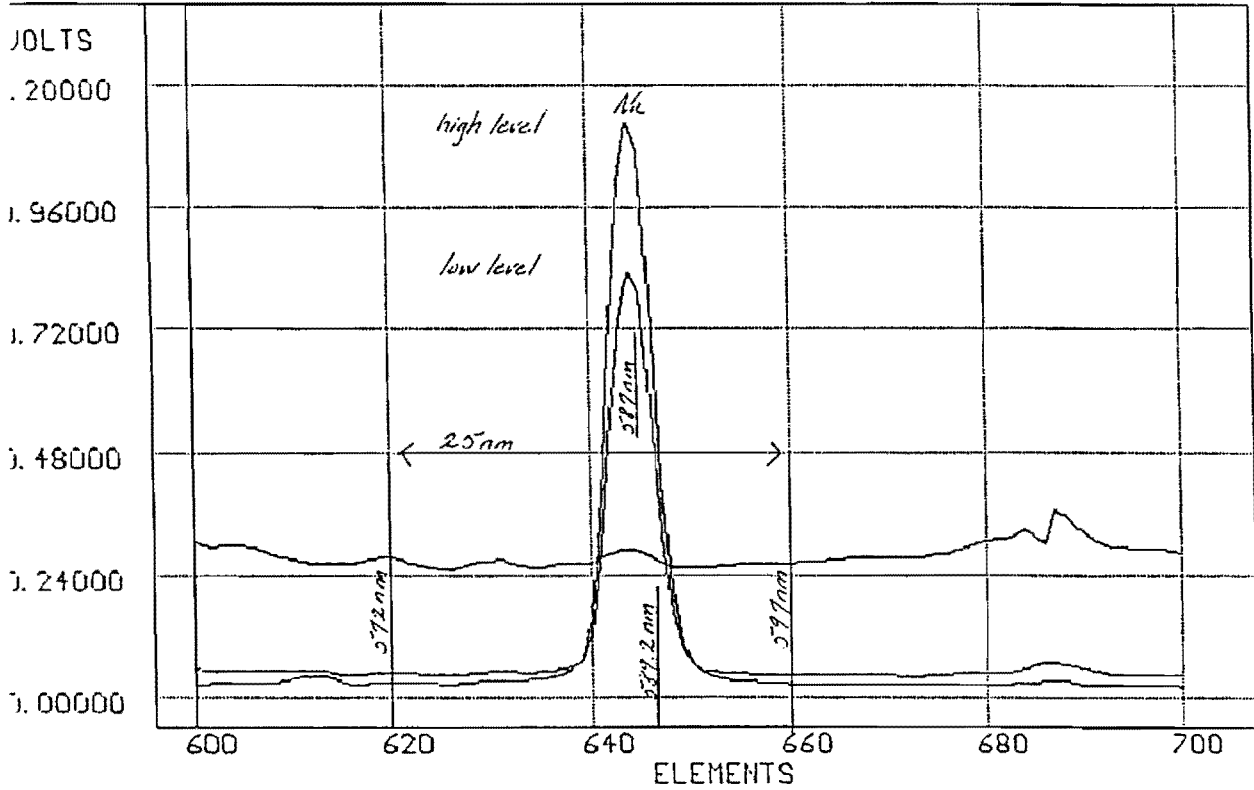

FILE 0: Standard

FILE 3: \data\ae_1cacl

FILE 1: \data\ae2dih20

FILE 4: \data\mgclcacl

FILE 2: Figure 13. Atomic Emission Spectra Oxygen Quenching with added CaCl

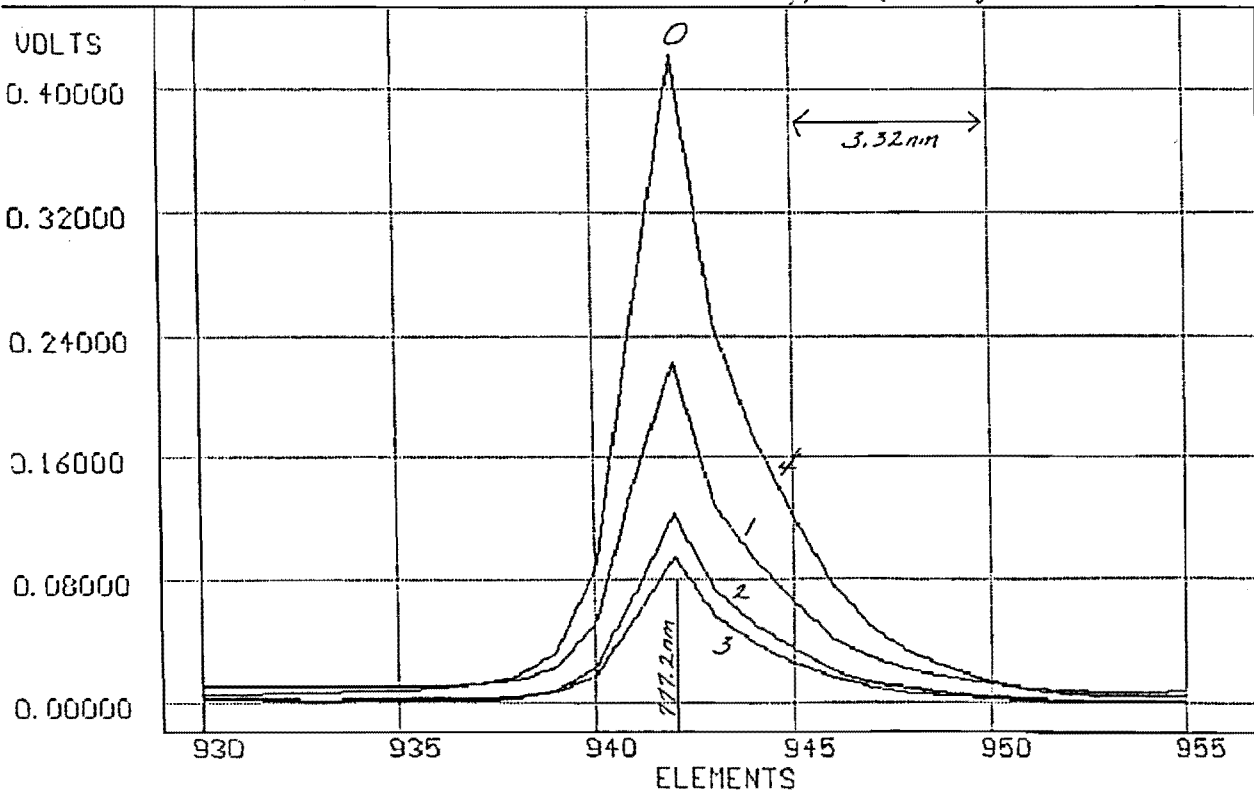

RUN DESCRIPTION:

FILE NAME: \ae\100s04_3

Figure 14 Atomic Emission Spectra Nutrient Solution

GAIN FACTOR: 10 NUMBER OF SCANS: 50 INTEGRATION TIME: 0.400 sec
 CLOCK RATE: 50 kHz RUN NUMBER: 1 of 1 TIME BETWEEN RUNS: 1.0 min

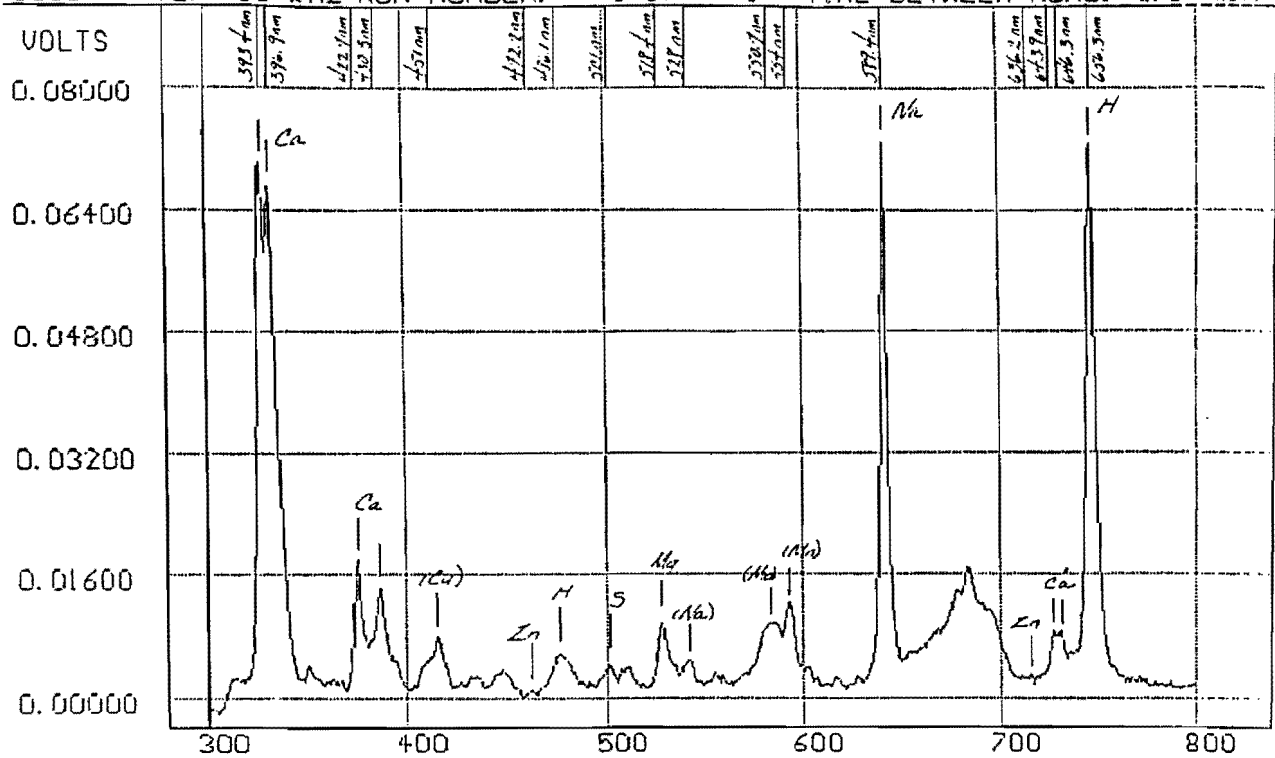

RUN DESCRIPTION:

FILE NAME: \ae\100s04_3.p

100 ppm S04 in nutrient solution 7 24 90

Figure 15 Atomic Emission Spectra Nutrient Solution

GAIN FACTOR: 10 NUMBER OF SCANS: 50 INTEGRATION TIME: 0.400 sec
 CLOCK RATE: 50 kHz RUN NUMBER: 1 of 1 TIME BETWEEN RUNS: 1.0 min

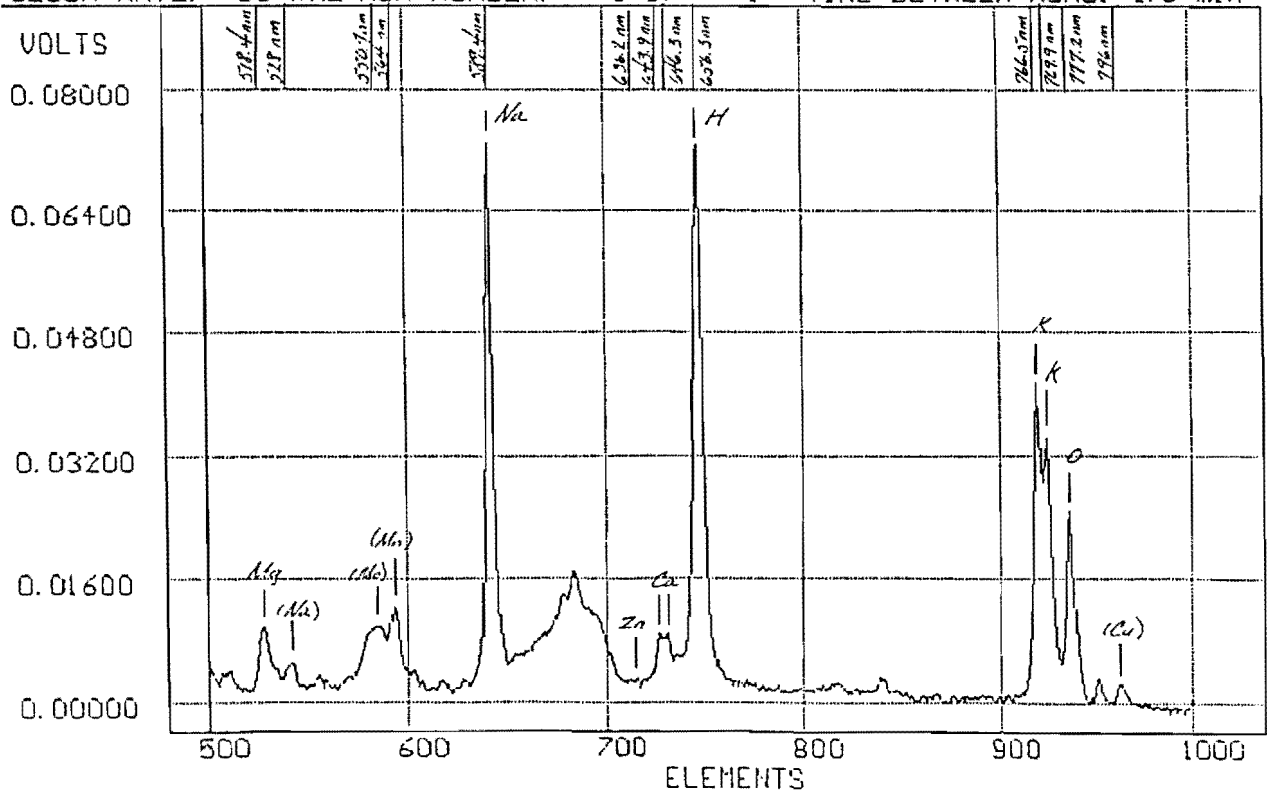

molybdenum, manganese, potassium and oxygen lines are indicated. Multiple lines are evident for many elements. Lines indicated by element symbols in parentheses have been identified but not quantified. Other element lines have responded to chemical concentration variations. It is noteworthy that many low (micromolar) concentration elements such as copper and molybdenum had significant emission intensities.

SUMMARY OF LAES TEST RESULTS

The extremely rich information content of Liquid Atomic Emission Spectrometry (LAES) is evident from the above results. There seems little question that most nutrients will generate atomic (and ionic) spectra detectable by LAES. It should also be emphasized that the Hybrid Absorption/Emission Array Spectrometer used for these measurements was not optimized for atomic line measurements. Ultraviolet absorption spectra, the original target of the instrument, have broad band characteristics as compared to atomic emission spectra. Significant changes in optical resolution are possible that can improve resolution and sensitivity by at least an order of magnitude. The detection of analytes at low ppm levels with broad band optics indicates that sensitivity goals for CELSS analytes can be achieved.

FINDINGS AND CONCLUSIONS

All of the original eight (8) analyte project objectives were demonstrated as measurable on-line by one or more forms of spectrometry as follows:

1. Potassium - LAES, secondary absorbance
2. Magnesium - LAES, secondary absorbance
3. pH - LAES, secondary absorbance
4. Calcium - LAES, secondary absorbance
5. Nitrogen (nitrate) - primary absorbance
6. Phosphorous (phosphate) - primary absorbance, secondary absorbance
7. Iron - LAES, primary absorbance secondary absorbance
8. Sulfur (sulfate) - LAES, primary absorbance, secondary absorbance

The remaining CELSS nutrient analytes listed in Table I are also measurable on-line using the same three techniques described for the objective analytes above. Many of these other analytes such as sodium, copper and zinc have been tested using one or more of the three spectrometric technologies.

A major result of this development was that all of the above on-line measurements can be performed by one on-line multi-purpose instrument, the Hybrid Absorption/Emission Array Analyzer. This analyzer can perform primary and secondary absorbance measurements as well as the new Liquid Atomic Emission (LAES) measurements.

The overall conclusion from all of the above findings is that the Hybrid Absorption/Emission Analyzer, utilizing two forms of spectrometric measurement, molecular absorbance and atomic emission, will be able, with further development, to provide comprehensive on-line analysis of all nutrients in an experimental CELSS facility.

REFERENCES

1. [Gui 73] Guilbault, George G., Practical Fluorescence, Marcel Dekker, 1973.
2. [Jon 88] Jones, T.P. and Porter, M.D., "Optical pH Sensor Based on the Chemical Modification of a Porous Polymer Film", Analytical Chemistry 60, 404-406, 1988.
3. [Lan 66] Land, D.B. and Edmonds, S., "A Fluorometric Method for Determining Trace Quantities of Phosphate", Mikrochim Acta, 1013, 1966.
4. [Met 87] Metcalfe, Ed., Atomic Absorption and Emission Spectroscopy, Wiley, 1987.
5. [Ott 85] Otto, M. and Wegscheider, W., "Spectrophotometric Multicomponent Analysis Applied to Trace Metal Determinations", Analytical Chemistry 57, 63-69, 1985.
6. [Schr 75] Schrenk, W.G., Analytical Atomic Spectroscopy, Plenum Press, 1975.
7. [Sib 84] Sibbald, A. et. al., "Simultaneous On-Line Measurement of Blood K^+ , Ca^{2+} , Na^+ and pH with a Four-Function ChemFET Integrated-Circuit Sensor", Clinical Chemistry 30, No. 1, 135, 1984.
8. [Zhu 84] Zhujun, Z. and Seitz, W.R., "A Fluorescence Sensor for Quantifying pH in the Range of 6.5 to 8.5", Analytical Chimica Acta, 160, 47-55, 1984.